

IP65/IP66 SECURITY CABINETS





New Generation Pole Type Security Cabinet



Ager New Generation SECURITY Pole Type Cabinet, New Design, 90 degree Cornered, Hidden hinge, closing over flange double-skinned front door, double-wall, 8mm insulation material between the walls, Outer Wall 1,5mm, Inner Wall 1,0mm - Dual-Volume, Single cycle 2 way fan + thermostat ventilation system, Top Cover Hinged with Stopper, Socket Type Cable Entry 1 pcs, Camera Assembly Place 4 pcs, Camera Assembly Place Cover Plate 4 pcs, Standard Zamac 3 point handled lock, DIN Rail in appropriate size 3pcs, UPS Shelf, The fresh air inlet with removable cleanable filters, slotted ventilation compartment shelf that allows air to pass between the two compartments and dedicated shelf for the extra device / modem / switch are standard for the Cabinet.

Cable Management Rings, Lighting Module, Door switches, Heavy Duty Type Pole Assembly Kit, Clamp Type Pole Fixing kit are accessories. No power socket module is added but if requested. Plastic or Aluminium Power Socket can be supplied. RAL 7035 is Light Grey Color is standart



Security Cabinet

AGER Security Cabinets with Pole mount version , enable protecting your valuable and sensitive equipments with its unique design. It is well protected against rain, snow, wind, sun radiation and earthquakes. With its perfect resistance to corrosion , protects your technological investments against environmental effects. There is 8.mm thick-ness isolation material

Isolation of Security Cabinet

Double Wall Structure with insulation is an effective solution to minimize environmental and territorial effects. The filtered panels allows ambient cold&fresh air to get in to the cabinet and reduces the internal heat naturally. Circulation fans are used to discharge the hot air from inside and by reducing heat it protects your active components.

Cabinet Structure

Cabinets are designed as Double Wall Structure, Material is DX51D+ZN275 gr/m2 zinc plated. According to EN 61587-1 / 6.4 IEC 60529 IP66 Protection class maintained based on solid body entries and water ingress. Fan and filter combinations attached provides IP54 protection class. Three Point locking system helps maintaining the IP66 protection class. Mono-block welded structure, RAL 7035 light grey polyester outdoor painting finish protects the cabinet from corrosion. Un-flammable and fire retardant painting is applied.

Filtered and Fan System

The cabinet has a replacable filter housing, which eliminates water and dust entry while allowing fresh air entry to the cabinet. The upper chasis of cabinet is equipped with 2 way fan including thermostat. The canopy roof is hinged and allows external access to the fan module for replacement and maintenance. Single cycle 2 way fan system allows fresh air entry from bottom and discharge accumulated heat from the ventilation slots under the canopy.



Double Wall Structure

Double Wall and isolation infilled panels protects the equipments inside cabinet from external effects, mechanical impacts, vandalism, harsh environmental conditions. External skin is 1,5mm DX51D+ZN275 zinc plated steel material structure with nano technology, high corrosion resistance polyester outdoor electrostatic painting applied. Inner skin is 1,0mm DX51D+ZN275 zinc plated steel material with painting. Between outer and inner skins there is 8mm isolation material.



Easy Pole Assembly

Special designed pole assembly brackets allows the cabinet to be hanged over the pole, after internal assembly is finished. Clamp Type Pole Fixing Kit is standard.

- Heavy Duty Type Pole Assembly Kit is optional

Painting

Outdoor style polyester paint applied to resist environmental corrosive effects. It also resists to sun radiation. Standard applied color is RAL7035 Light Grey.

Camera Assembly

There is 4 pieces camera mounting places, In standard those camera assembly provisions covered with metal plates. Mostly 1 mobile and 3 fixed cameras used in standard applications.

DIN Rails

There are 3 pcs DIN rails in sufficient sizes which are available to place industrial devices and electrical equipments.



Lighting

By the automatic LED lighting unit that illuminates when door is opened and allows visibility to inside of cabinets during nights or dark environment conditions. Site operations can run continuously. It can be supplied as an accessory

Movable UPS Shelf

The wheeled and movable structure of UPS shelf allows to read the front panel of the device. It can be pushed back after the control process ends.

Fixed Shelf

In this dual-volume product model, the partition separator is fixed as it has shelf feature. This compartment shelf is positioned between the lower and upper compartment. Slotted structure of shelf does not prevent air Ocirculation.



Shelf for Modem, Switch, Device

There is a separate shelf structure on the upper right partition of the enclosure which allows to accommodate modem-switch or such devices.

Top Cover Canopy Structure

Top cover canopy system allows to maintenance cleaning and changing of fan module while the system on going inside the cabinet. Stopper mechanism is hidden inside top cover. This feature keeps the top cover open while installation or maintenance is in process on the field.

Corner and Top Cover Structure

90 degree corner structured. Top cover is flat type.

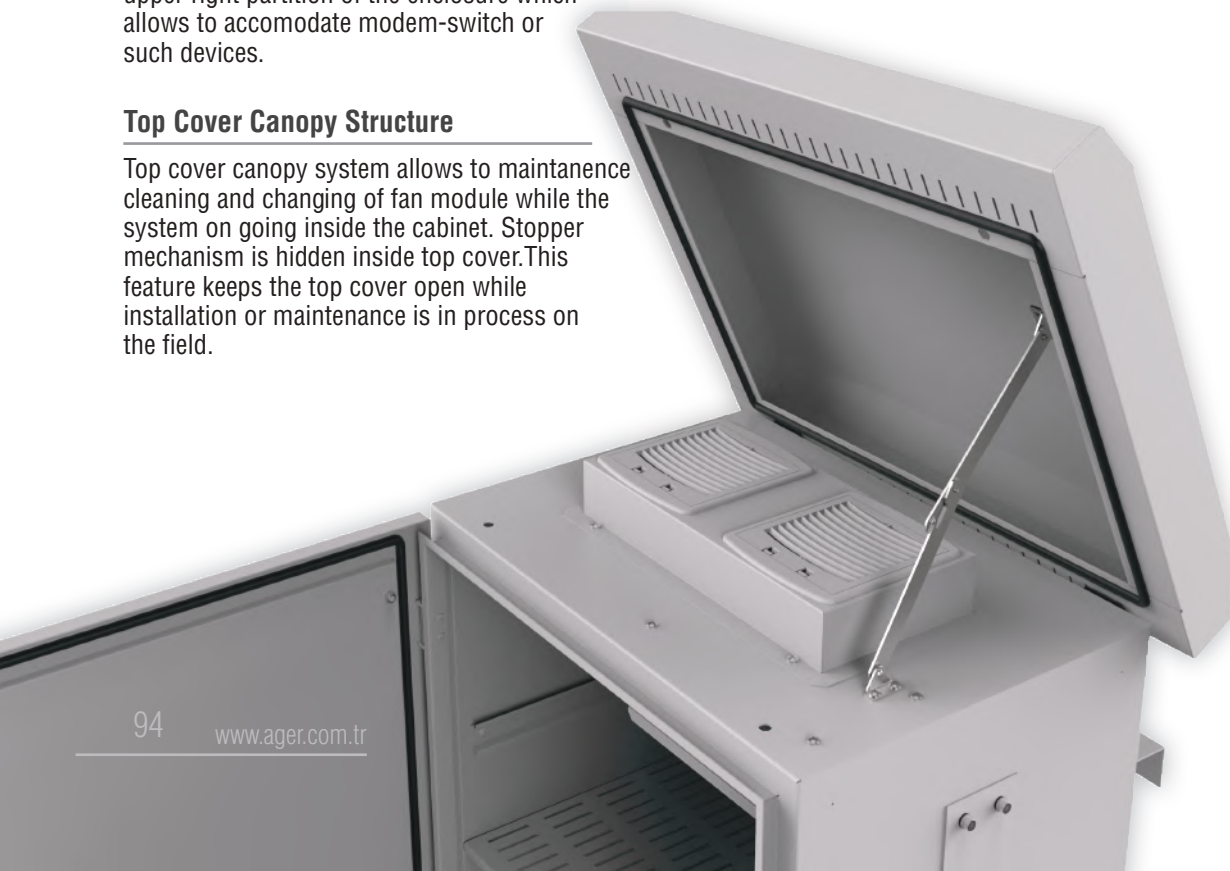

Front door and Lock System

Hidden hinge, closing over flange double-skinned front door structure is available. Standard Zamac - 3 point locking system provides maximum security and impermeability. Resistant to the extreme weather conditions Polyurethane Foam Gasket is used that provides Water and Dust Proof.

Door Switch

To receive a warning when the front door of cabinet opened or to enable or disable other systems , doors switches can be integrated. 1 or 2 switch integrations can be provided as an accessory.



Cable Management Rings

By using the self-threaded special screw system, cable management rings -as an accessory - can be placed anywhere in the interior surface of the cabinet in desired quantities to set up cable management infrastructure

PDU

On/off Plastic 6 way PDU can be provided as an accessory. Please refer accessory chart.

Cable Entry

There are 3 types of cable entry. Socket type, 90 degree protected pipe type and 45 degree protected pipe type. All 3 types have feature that can be used for the same product. Socket type is used in standard configuration. In case of need for different type cable entry, please choose cable entry model that you need from accessory chart

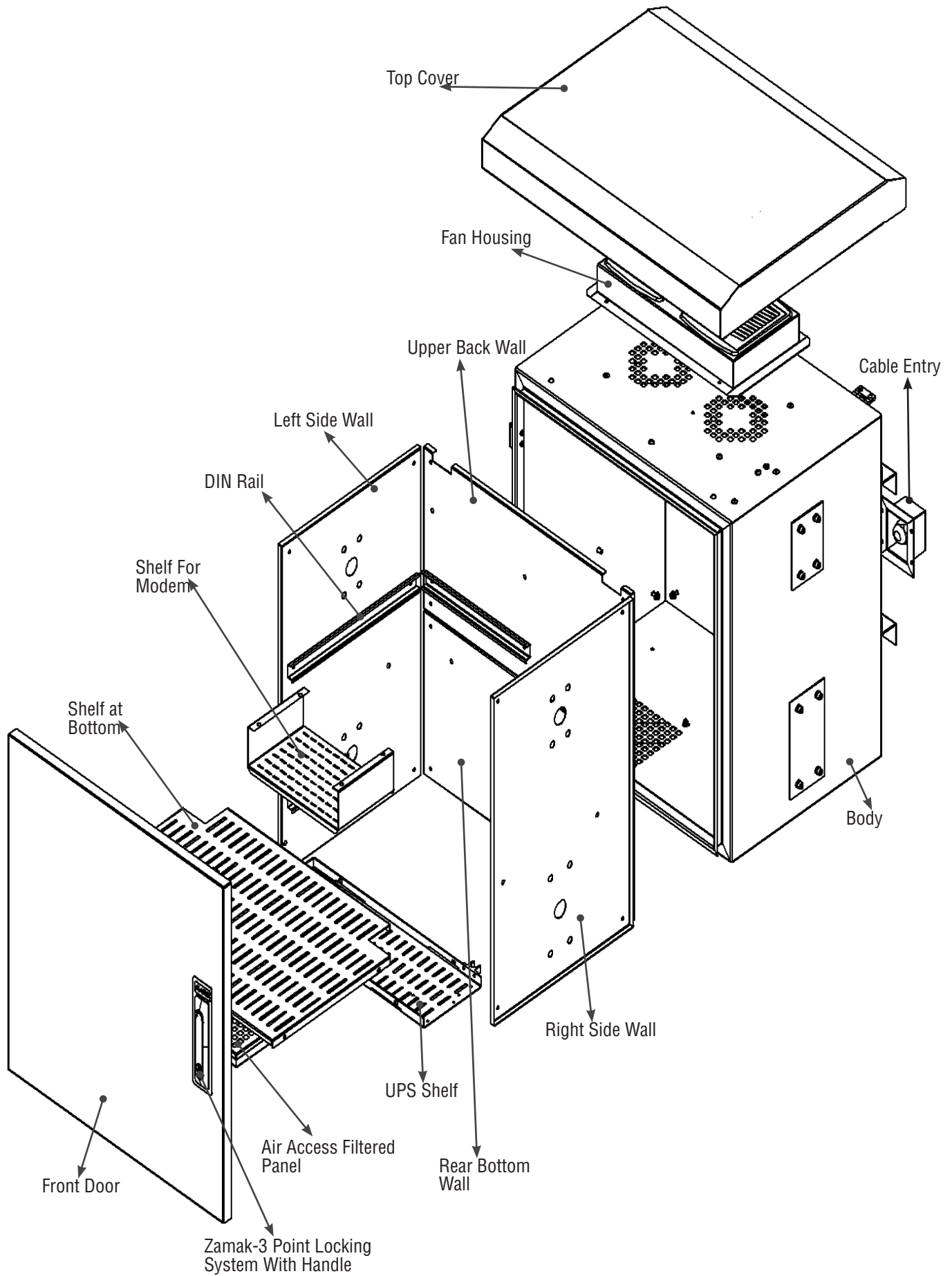

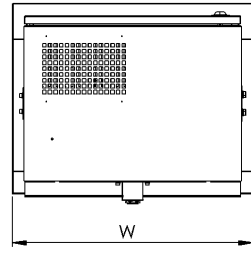

Bottom View

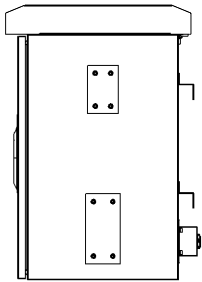

Side View

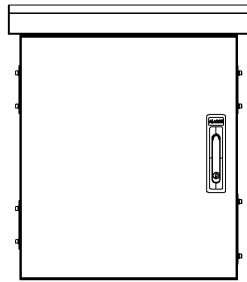

Front View

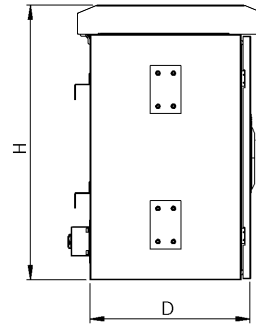

Side View

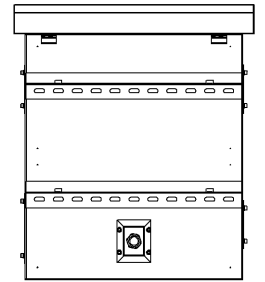

Rear View

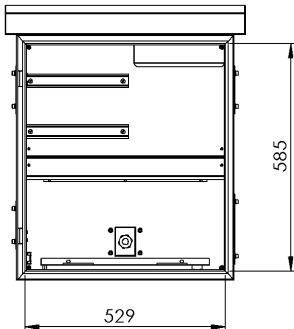

Front View Without Door

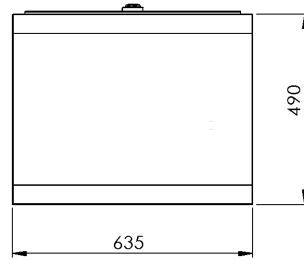

Top View

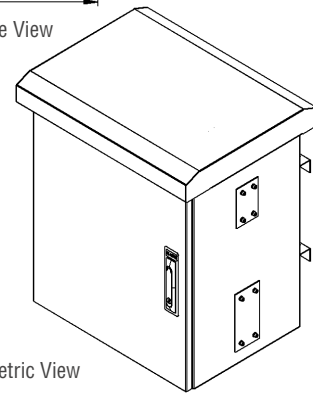

Isometric View

New Generation Pole Type Security Cabinet

| Product Code | Product Description | Height Size in (U) | Width (w) (mm) | Depth (D) (mm) | Height (H) (mm) | Weight (Net) (kg) | Weight (Gross) (kg) |
|----------------------|---|--------------------|----------------|----------------|-----------------|-------------------|---------------------|
| AG-MB577043B2-D-A-M1 | AGER New Generation Pole Type Security Cabinet- RAL 7035 Light Gray | - | 575 | 430 | 706 | 66 | 68 |



A Type Midi Pole Type Security Cabinet



Ager New Generation SECURITY Pole Type Cabinet, New Design, 90 degree Cornered, Hidden hinge, closing over flange double-skinned front door, double-wall, 8mm insulation material between the walls, Outer Wall 1,5mm, Inner Wall 1,0mm - Dual-Volume, Single cycle 2 way fan + thermostat ventilation system, Top Cover Hinged with Stopper, Clamp Type Pole Fixing kit, Socket Type Cable Entry 1 pcs, 19" 7U mounting rail 1set=2pcs, Camera Assembly Place 4 pcs, Camera Assembly Place Cover Plate 4 pcs, Standard Zamac single point handled lock, DIN Rail in appropriate size 3pcs, UPS Shelf, The fresh air inlet with removable cleanable filters are standard for the Cabinet. Cable Management Rings, Lighting Module, Door switches / switches are accessories. No power socket module is added but if requested. Plastic or Aluminium Power Socket can be supplied. RAL 7035 is Light Grey Color is standart



Security Cabinet

AGER Security Cabinets with Pole mount version , enable protecting your valuable and sensitive equipments with its unique design. It is well protected against rain, snow, wind, sun radiation and earthquakes. With its perfect resistance to corrosion , protects your technological investments against environmental effects. There is 8.mm thickness isolation material

Isolation of Security Cabinet

Double Wall Structure with insulation is an effective solution to minimize environmental and territorial effects. The filtered panels allows ambient cold&fresh air to get in to the cabinet and reduces the internal heat naturally. Circulation fans are used to discharge the hot air from inside and by reducing heat it protects your active components.

Cabinet Structure

Cabinets are designed as Double Wall Structure, Material is DX51D+ZN275 gr/m2 zinc plated. According to EN 61587-1 / 6.4 IEC 60529 IP66 Protection class maintained based on solid body entries and water ingress. Fan and filter combinations attached provides IP54 protection class. Three Point locking system helps maintaining the IP66 protection class. Mono-block welded structure, RAL 7035 light grey polyester outdoor painting finish protects the cabinet from corrosion. Un-flammable and fire retardant painting is applied.



Double Wall Structure

Double Wall and isolation infilled panels protects the equipments inside cabinet from external effects, mechanical impacts, vandalism, harsh environmental conditions. External skin is 1,5mm DX51D+ZN275 zinc plated steel material structure with nano technology , high corrosion resistance polyester outdoor electrostatic painting applied. Inner skin is 1,0mm DX51D+ZN275 zinc plated steel material with painting. Between outer and inner skins there is 8mm isolation material.

Corner and Top Cover Structure

90 degree corner structured. Top cover is flat type.



Filtered and Fan System

The cabinet has a replacable filter housing, which eliminates water and dust entry while allowing fresh air entry to the cabinet. The upper chasis of cabinet is equipped with 2 way fan including thermostat. The canopy roof is hinged and allows external access to the fan module for replacement and maintenance. Single cycle 2 way fan system allows fresh air entry from bottom and discharge accumulated heat from the ventilation slots under the canopy.

Easy Pole Assembly

Special designed pole assembly brackets allows the cabinet to be hanged over the pole, after internal assembly is finished. Clamp Type Pole Fixing Kit is standard.

Camera Assembly

There is 4 pieces camera mounting places, In standard those camera assembly provisions covered with metal plates. Mostly 1 mobile and 3 fixed cameras used in standard applications.



19" Mounting Rail Assembly

19" 7U usable sized, thickness 1,5mm 1 set:2 pcs mounting profile is available with U marking. All 19" accessories can be used.

Movable UPS Shelf

The wheeled and movable structure of UPS shelf allows to read the front panel of the device. It can be pushed back after the control process ends.

DIN Rails

There are 3 pcs DIN rails in sufficient sizes which are available to place industrial devices and electrical equipments.

Fixed Shelf

Product has 7U mounting profile. Separation shelf is not in standard shipping configuration. A rack mount shelf can be used as a separator. Please see accessory chart. .

Lighting

By the automatic LED lighting unit that illuminates when door is opened and allows visibility to inside of cabinets during nights or dark environment conditions. Site operations can run continuously. It can be supplied as an accessory

Door Switch

To receive a warning when the front door of cabinet opened or to enable or disable other systems , doors switches can be integrated. 1 or 2 switch integrations can be provided as an accessory.

Painting

Outdoor style polyester paint applied to resist environmental corrosive effects . It also resists to sun radiation. Standard applied color is RAL7035 Light Grey.

Cable Management Rings

By using the self-threaded special screw system, cable management rings -as an accessory - can be placed anywhere in the interiorsurface of the cabinet in desired quantities to set up cable management infrastructure



Top Cover Canopy Structure

Top cover canopy system allows to maintenance cleaning and changing of fan module while the system on going inside the cabinet. Stopper mechanism is hidden inside top cover.This feature keeps the top cover open while installation or maintenance is in process on the field.

Front Door and Lock System

Hidden hinge, closing over flange doubleskinned front door structure is available. Standard Zamac - 3 point locking system provides maximum security and impermeability. Resistant to the extreme weather conditions Polyurethane Foam Gasket is used that provides Water and Dust Proof.

PDU

On/off Plastic 6 way PDU and Aluminium options can be provided as an accessory. Please refer accessory chart.

Cable Entry

There are 3 types of cable entry. Socket type , 90 degree protected pipe type and 45 degree protected pipe type . All 3 types have feature that can be used for the same product. Socket type is used in standard configuration. In case of need for different type cable entry, please choose cable entry model that you need from accessory chart

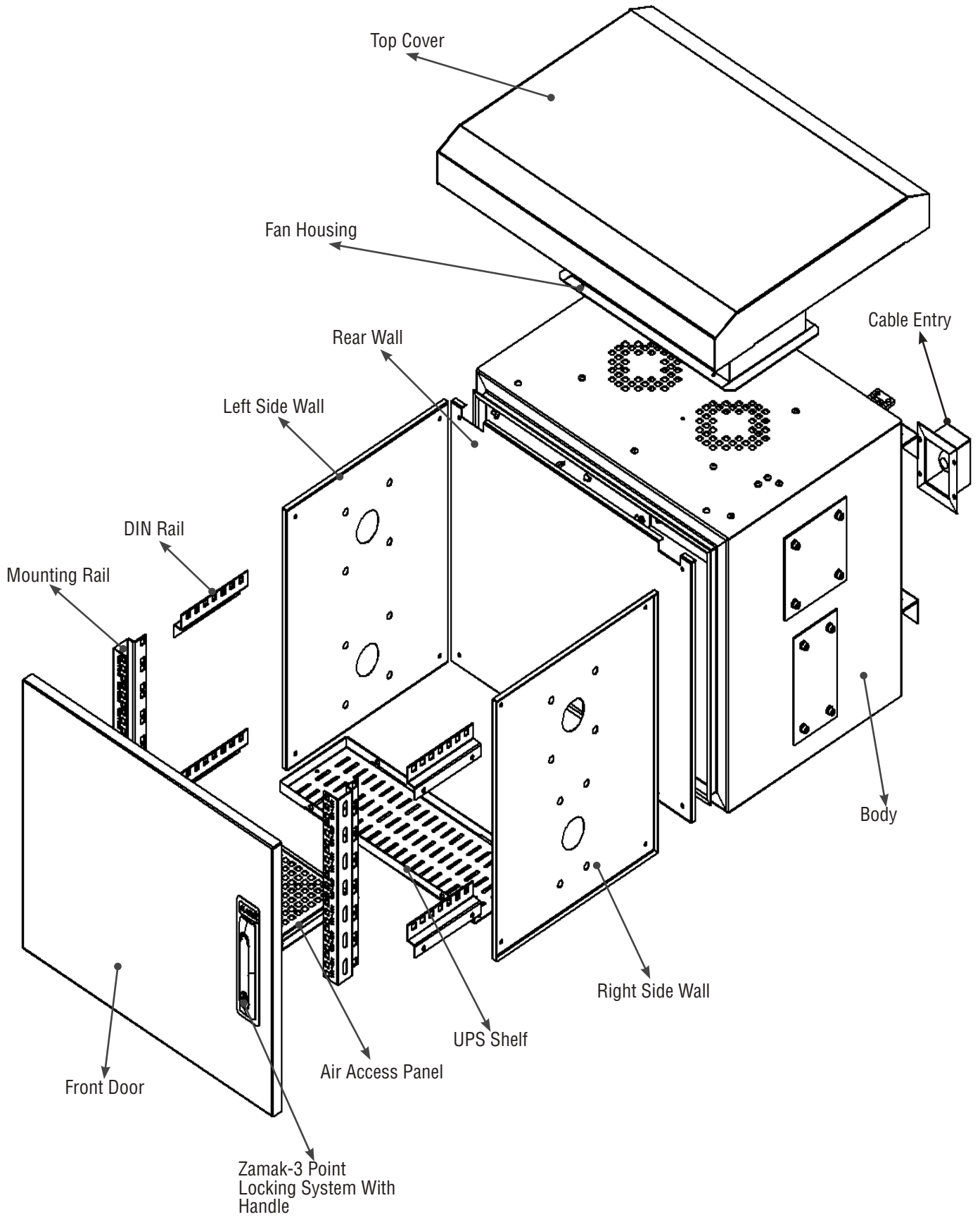

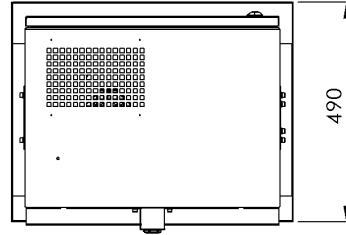

Bottom View

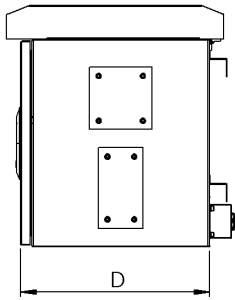

Side View

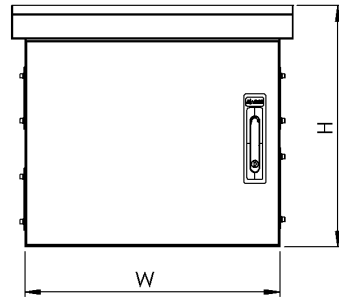

Front View

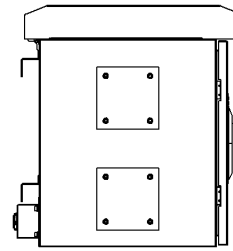

Side View

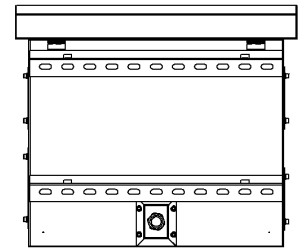

Rear View

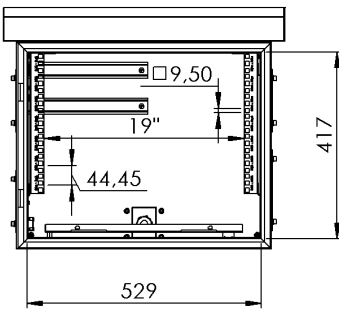

Front View Without Door

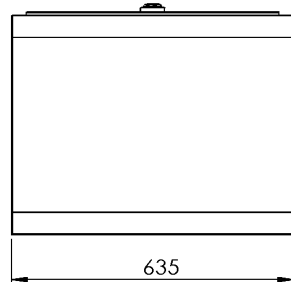

Top View

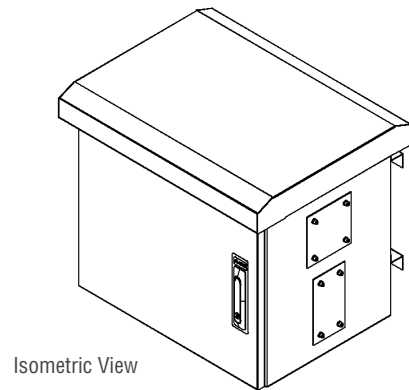

Isometric View

A Type Midi Pole Type Security Cabinet

| Product Code | Product Description | Height Size in (U) | Width (mm) | Depth (D) (mm) | Height (H) (mm) | Weight (Net) (kg) | Weight (Gross) (kg) |
|-----------------------|---|--------------------|------------|----------------|-----------------|-------------------|---------------------|
| AG-MB-575442B2-D-A-M1 | AGER A TYPE MIDI POLE TYPE SECURITY CABINET- RAL 7035 White | - | 575 | 425 | 540 | 47 | 49 |



Mini Pole Type Security Cabinet Kabinet Basic Model



Ager MINI SECURITY Pole Type Cabinet, Basic Model, 90 degree Cornered, Hidden hinge closing over flange double-skinned front door, double-wall, 8 mm insulation material between the walls, Outer Wall 1,5mm painted, Inner Wall 1mm unpainted galvanized steel sheet- Single-Volume, Single Cycle 1Fan+Thermostat Ventilation System, Hinged Top Cover, Clamp Type Pole Fixing kit, 90 degree pipe protected type 1 pcs of cable entry, Camera Assembly Place 4 pcs, Camera Assembly Place Cover Plate 4pcs, Single Point Barrel Type Economic Lock, DIN Rail in appropriate size 2pcs, UPS Shelf The fresh air inlet removable cleanable filter are standard

Lighting Module, Cable Management Rings, Door switches / switches are added as accessories. No power socket module is added but if requested. Plastic or Aluminium Power Module can be supplied (NOT 19"). RAL 7035 Light Grey Color.



Security Cabinet

Ager Security Cabinets with Pole mount version, enable protecting your valuable and sensitive equipments with its unique design. It is well protected against rain, snow, wind, sun radiation and earthquakes. With its perfect resistance to corrosion, protects your technological investments against environmental effects. Overall between the inner and outer skin there is 8 mm thickness isolation material.

Isolation of Security Cabinet

Double skin structure with insulation is an effective solution to minimize environmental and territorial effects. The filtered panels allows ambient cold&fresh air to get in to the cabinet and reduces the internal heat naturally. Circulation fans are used to discharge the hot air from inside and by reducing heat it protects your active components.



Cabinet Structure

Cabinets are designed as double skin structure, Material is DX51D+ZN275 gr/m² zinc plated. According to EN 61587-1 / 6.4 IEC 60529 IP66 Protection class maintained based on Solid body entries and Water ingress.Fan and Filter combinations attached provides IP54 protection class. Zamac Type - Single Point locking system helps maintaining the IP66 protection class. Mono-block welded structure, RAL 7035 light grey polyester outdoor painting finish protects the cabinet from corrosion. Un-flammable and fire retardant painting is applied.



Double Wall Structure

Double Skin and isolation infilled panels protects the equipments inside cabinet from external effects, mechanical impacts, vandalism, harsh environmental conditions. External skin is 1,5mm DX51D+ZN275 zinc plated steel material structure with nano technology , high corrosion resistance polyester outdoor electrostatic painting applied. Inner skin is 1,0mm DX51D+ZN275 zinc plated steel material without painting.Between outer and inner skins there is 8 mm isolation material.

Corner and Top Cover Structure

90 degree corner structured. Top cover is flat type.

Filtered and Fan System

The cabinet has a replacable filter housing, which eliminates water and dust entry while allowing fresh air entry to the cabinet. The upper chasis of cabinet is equipped with single fan including thermostat. The canopy roof is hinged and allows external access to the fan module for replacement and maintenance. Single cycle fan allows fresh air entry from bottom and discharge accumulated heat from the ventilation slots under the canopy



Easy Pole Assembly

Special designed pole assembly brackets allows the cabinet to be hanged over the pole, after internal assembly is finished. Clamp type bracket system allows easy attach of enclosure to the pole. Clamp type pole fixing brackets are included.

Camera Assembly

There is 4 pieces camera mounting places, In standard those camera assembly provisions covered with metal plates. Mostly 1 mobile and 3 fixed cameras used in standard applications.



DIN Rails

There are 2 pcs DIN rails in sufficient sizes which are available to place industrial devices and electrical equipments.

Front Door Yapısı ve Klit Sistemi

Hidden hinge, Flange flush mounted double skin front door structure is available. barrel type - single point locking and gasket system provides maximum security and impermeability. It has a sealing gasket structure. Thanks to the excellent sealing Polyurethane foam based long life sealing system, provides excellent IP protection even cold/hot wheather condition.

Lighting

By the automatic LED lighting unit that illuminates when door is opened and allows visibility to inside of cabinets during nights or dark environment conditions. Site operations can run continuously. It can be supplied as an accessory.

Door Switch

To receive a warning when the front door of cabinet opened or to enable or disable other systems , doors switches can be integrated. 1 or 2 switch integrations can be provided as an accessory. .

Painting

Outdoor style polyester paint applied to resist environmental corrosive effects . It also resists to sun radiation. Standard applied color is RAL7035 Light Grey.

Top Cover Canopy Structure

Hinged top cover module allows you to operate, maintain, repair, clean, installation from outside while system runs.



Cable Management Rings

By using the self-threaded special screw system , cable management rings -as an accessory - can be placed anywhere in the interior surface of the cabinet in desired quantities to set up cable management infrastructure.

PDU

On/off Plastic 6 way PDU can be provided as an accessory. Please refer accessory chart.

Cable Entry

There are 3 types of cable entry. Socket type , 90 degree protected pipe type and 45 degree protected pipe type . All 3 types have feature that can be used for the same product. 90 degree protected pipe type is used in standard configuration. In case of need for different type cable entry, please choose cable entry model that you need from accessory chart.

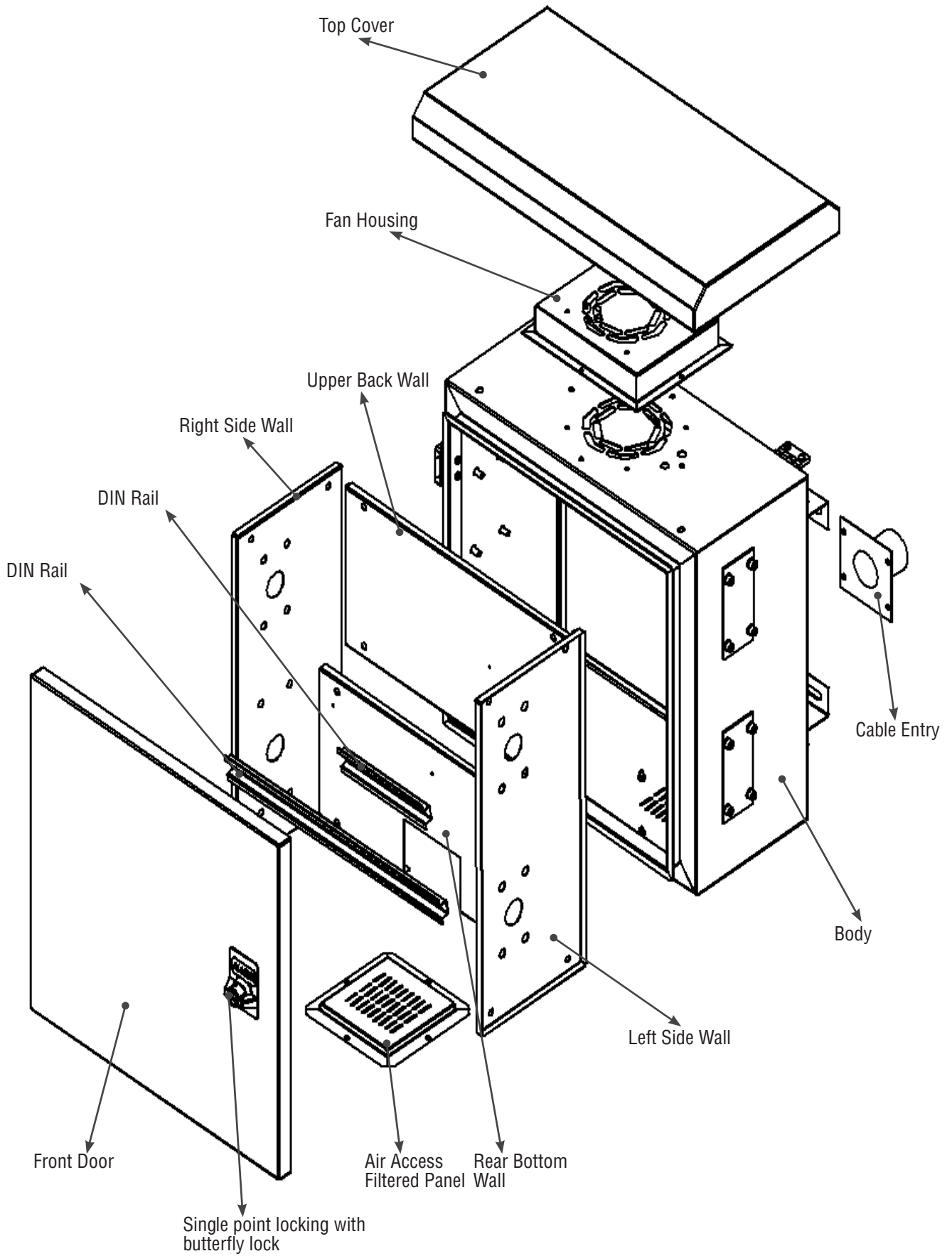

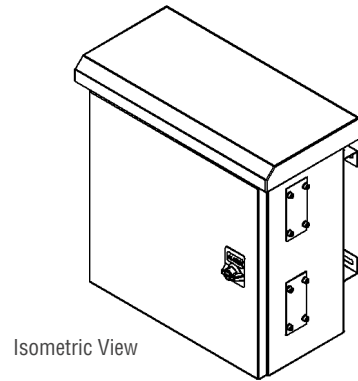
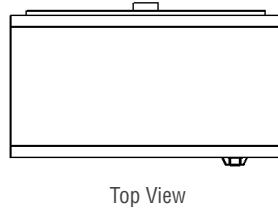
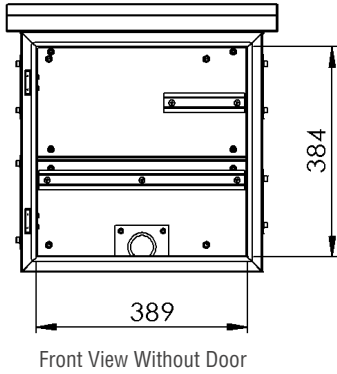
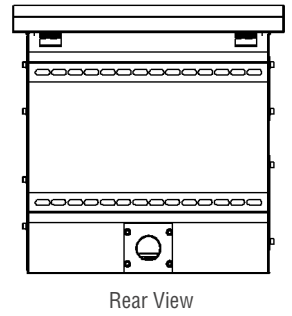
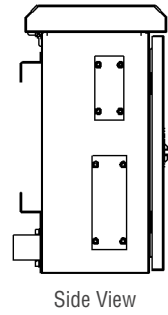
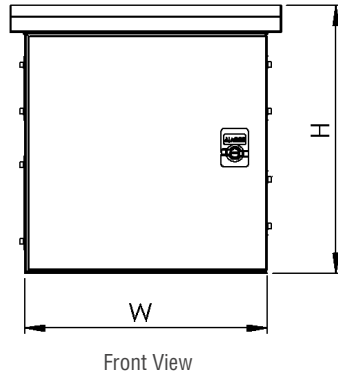
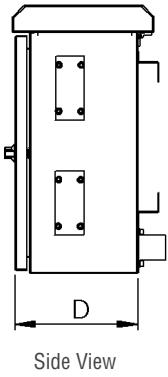
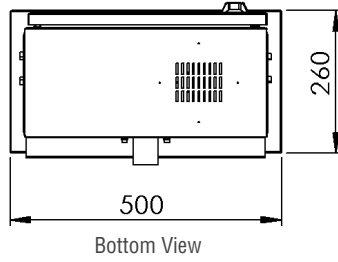

Mini Pole Type Security Cabinet Kabinet Basic Model

| Product Code | Product Description | Height Size in (U) | Width(w) (mm) | Depth (D) (mm) | Height (H) (mm) | Weight (Net) (kg) | Weight (Gross) (kg) |
|-----------------------|--|--------------------|---------------|----------------|-----------------|-------------------|---------------------|
| AG-MB-455023B2-D-A-M1 | AGER Mini Pole Type Security Cabinet Kabinet Basic Model- RAL 7035 White | - | 445 | 225 | 500 | 33 | 34,5 |

New Generation **B Type MIDI** Security Pole Type Cabinet



AGER New Generation B Type MIDI SECURITY Pole Type Cabinet, 90 degree Cornered, Hidden hinge closing over flange double-skinned front door, double-wall, 8mm insulation material between the walls, Outer Wall 2,0mm, Inner Wall 1mm- Dual-Volume, Single cycle 2 way fan + thermostat ventilation system, Hinged Top Cover, Heavy Duty or Economic Clamp Type Pole Fixing kit is provided as an accessory. Socket Type Cable Entry 1 pcs of cable entry is available, 19" mounting rail CANNOT be included as the cabinet is not in 19" standards, Camera Assembly Place 4 pcs, Camera Assembly Place Cover Plate 4 pcs, Standard Zamac Single Point Lock with Handle, Cable Management Rings are provided as accessories. DIN Rail in appropriate size 3 Pcs, Lighting Module is provided as an accessory. UPS shelf is not available, slotted ventilation compartment shelf that allows air to pass between the two compartments is available. Door switches / switches are added as accessories. No power socket module is added but if requested. Plastic Power Module can be supplied (NOT 19"). The fresh air inlet removable cleanable filter from inside is available. RAL 7035 is Light Grey Color



Security Cabinet

AGER Security Cabinets with Pole mount version , enable protecting your valuable and sensitive equipments with its unique design. It is well protected against rain, snow, wind, sun radiation and earthquakes. With its perfect resistance to corrosion , protects your technological investments against environmental effects. Overall between the inner and outer skin there is 8.mm thickness isolation material.

Isolation of Security Cabinet

To minimize environmental and territorial effects, the cabinet is designed with double skin structure, where in between there is 8mm isolation material. This isolation material is avoiding heat problems. On body there is filtered fresh air entry located, which via convection fresh air enters to cabinet, Circulation Fan Unit discharges the accumulated heat from enclosure with this structure protects the active components inside cabinet.

Cabinet Structure

Cabinets are designed as double skin structure, Material is DX51D+ZN275 gr/m2 zinc plated. According to EN 61587-1 / 6.4 IEC 60529 IP66 Protection class maintained based on Solid body entries and Water ingress. Fan and Filter combinations attached provides IP54 protection class. Fully EPDM gasketed front door is available. Zamac Type - Three Point locking system helps maintaining the IP66 protection class. Mono-block welded structure, RAL 7035 light grey polyester outdoor painting finish protects the cabinet from corrosion. Un-flammable and fire retardant painting is applied

Double Wall Structure

Double Wall and isolation infilled panels protects the equipments inside cabinet from external effects, mechanical impacts, vandalism, harsh environmental conditions. External skin is 1,5mm DX51D+ZN275 zinc plated steel material structure with nano technology, high corrosion resistance polyester outdoor electrostatic painting applied. Inner skin is 1,0mm DX51D+ZN275 zinc plated steel material without painting. Between outer and inner skins there is 8mm isolation material.

Corner and Top Cover Structure

90 degree corner structured. Top cover is flat type.





Filtered and Fan System

The cabinet has a replacable filter housing , which eliminates water and dust entry while allowing fresh air entry to the cabinet. The upper chasis of cabinet is equipped with two fan including thermostat. The canopy roof is hinged and allows external access to the fan module for replacement and maintenance. Single cycle 2 way fan system allows fresh air entry from bottom and discharge accumulated heat from the ventilation slots under the canopy

Easy Pole Assembly

Special designed pole assembly brackets allows the cabinet to be hanged over the pole, after internal assembly is finished. Clamp Type Pole Fixing Kit is standard

Camera Assembly

There is 4 pieces camera mounting places, In standard those camera assembly provisions covered with metal plates. Mostly 1 mobile and 3 fixed cameras used in standard applications.



DIN Rails

There are 3 pcs DIN rails in sufficient sizes which are available to place industrial devices and electrical equipments.

Lighting

By the automatic LED lighting unit that illuminates when door is opened and allows visibility to inside of cabinets during nights or dark environment conditions. Site operations can run continuously. It can be supplied as an accessory.

Fixed Shelf

In this dual-volume product model, the partition separator is fixed as it has shelf feature. This compartment shelf is positioned between the lower and upper compartment. Slotted structure of shelf does not prevent air circulation.

Painting

Outdoor style polyester paint applied to resist environmental corrosive effects . It also resists to sun radiation. Standard applied color is RAL7035 Light Grey.

Top Cover Canopy Structure

Stopper mechanism is hidden inside top cover. This feature keeps the top cover open while installation or maintenance is in process on the field.

Front door and Lock System

Hidden hinge, closing over flange double-skinned front door structure is available. Standard Zamac - 3 point locking system provides maximum security and impermeability. Resistant to the extreme weather conditions Polyurethane Foam Gasket is used that provides Water and Dust Proof.



Door Switch

To receive a warning when the front door of cabinet opened or to enable or disable other systems, door switches can be integrated. 1 or 2 switch integrations can be provided as an accessory.

Cable Entry

There are 3 types of cable entry. Socket type, 90 degree protected pipe type and 45 degree protected pipe type. All 3 types have feature that can be used for the same product. Socket type is used in standard configuration. In case of need for different type cable entry, please choose cable entry model that you need from accessory chart.

Cable Management Rings

By using the self-threaded special screw system, cable management rings -as an accessory - can be placed anywhere in the interior surface of the cabinet in desired quantities to set up cable management infrastructure.

PDU

On/off Plastic 6 way PDU can be provided as an accessory. Please refer accessory chart.

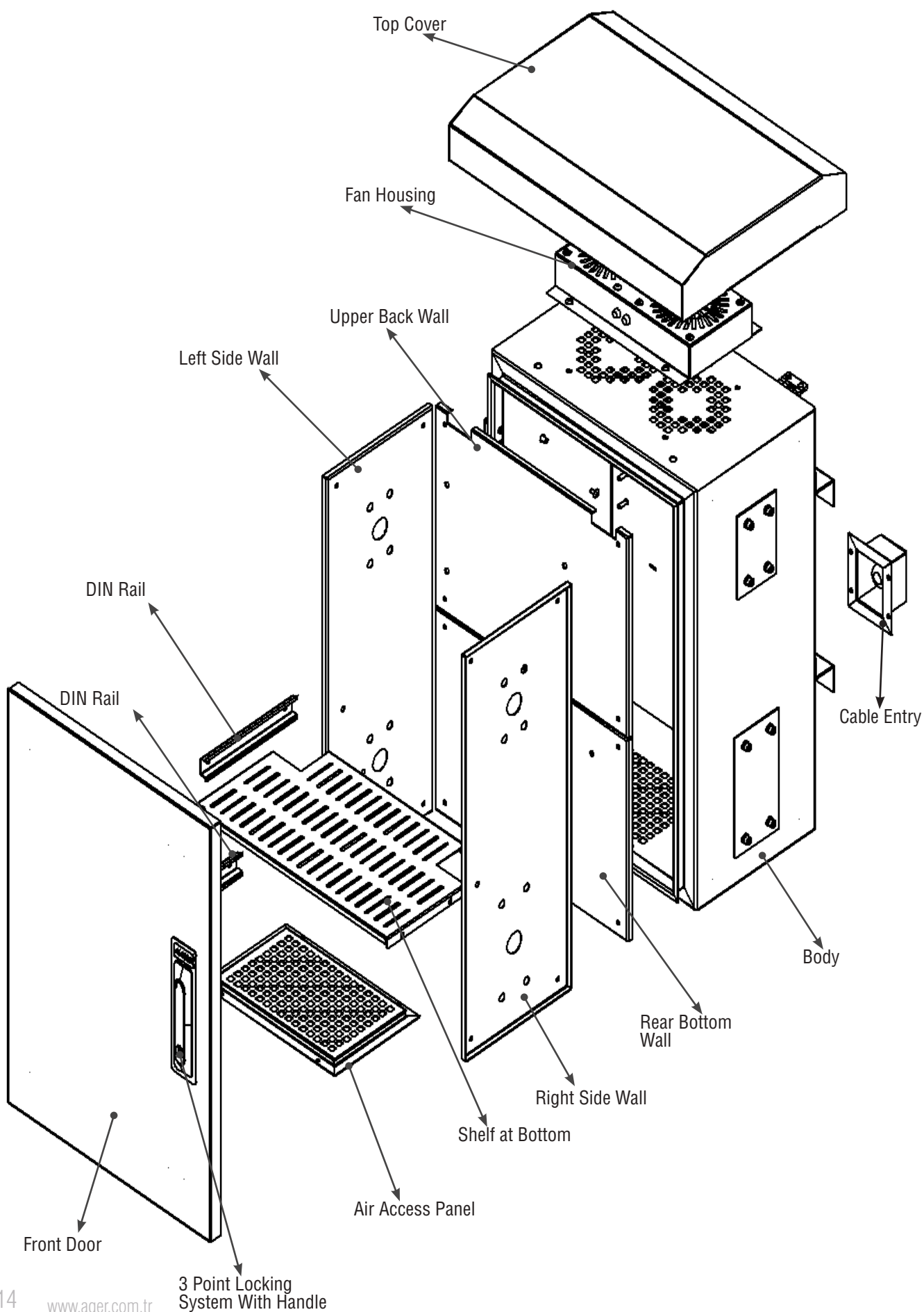

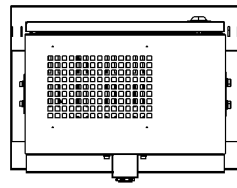

Bottom View

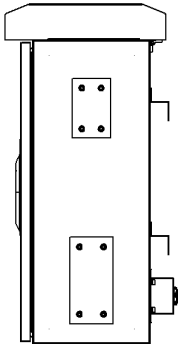

Side View

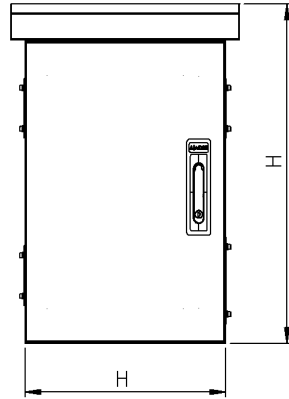

Front View

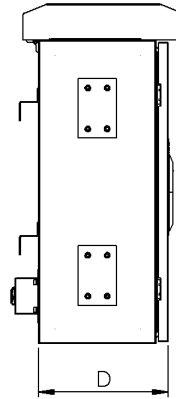

Side View

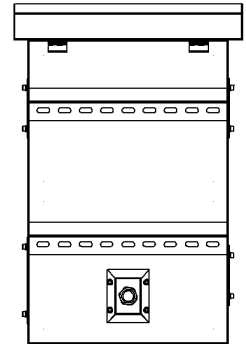

Rear View

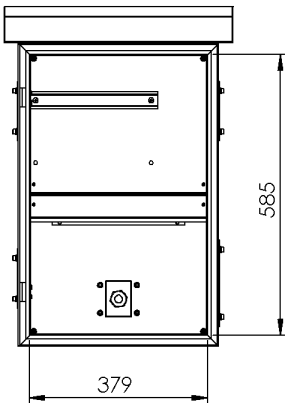

Front View Without Door

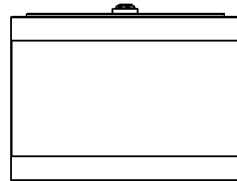

Top View

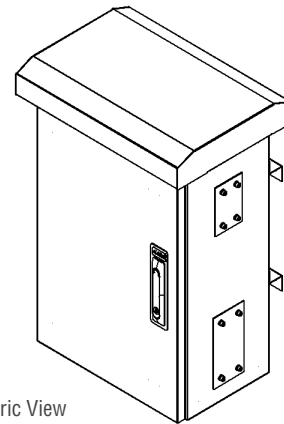

Isometric View

New Generation B Type MIDI Security Pole Type Cabinet

| Product Code | Product Description | Height Size In (U) | Width(w) (mm) | Depth (D) (mm) | Height (H) (mm) | Weight (Net) (kg) | Weight (Gross) (kg) |
|-----------------------|---|--------------------|---------------|----------------|-----------------|-------------------|---------------------|
| AG-MB-457028B2-D-A-M1 | AGER NEW GENERATION B TYPE MIDI SECURITY POLE TYPE CABINET- RAL 7035 WhiteL | - | 425 | 275 | 700 | 40,5 | 42 |



IP66 Field Enclosure Security Cabinet Floor Type-Pole Type

12U (19" 6U upper compartment and 6U size equivalent non 19" lower compartment - W600mm x D400/450/600mm Field Enclosure. 90 degree Cornered, Flanged system hinged door, double-wall, 8mm insulation material between the walls, Dual-Volume, Ventilation System with 2 different cycles 2Fan with Thermostat, crossfall structure Top Cover Hinged with Stopper. 6U 19" mounting rail is available at the upper compartment 1set-2 pcs. WK2 Antivandal lock with handle - 3 point locking is available. Cable Management Rings are provided as accessories. DIN Rail is supplied as an accessory. Lighting Module is provided as an accessory. UPS shelf is not available, there is a separate lockable inner cover for each compartment, there is a compartment shelf that does not make air pass between the two compartments. A dedicated shelf for the extra device / modem / switch is added as accessory. Door switch / switches are added as accessories. No power socket module is added but if requested. Choice of plastic or aluminium socket modules are supplied as accessory. The fresh air inlet removable cleanable filter from inside is available. RAL 7035 is Light Grey Color



Floor Type: Outer Wall 3 mm, Inner Wall 2 mm
H=100mm plinth is available. At the bottom gland cable entry is available. No camera mounting hole is available, Camera connections are recommended externally.

Pole Type: Outer Wall 1,5 mm, Inner Wall 1 mm
Heavy Duty or Economic Clamp Type Pole Fixing kit is provided as an accessory. 2 pcs of 90 degree pipe protected type cable entry is available. No camera mounting hole is available, Camera connections are recommended externally.



Security Cabinet

AGER Field enclosures -Security Cabinets with Pole mount and Floor type versions , enable protecting your valuable and sensitive equipments with its unique design. It is well protected against to rain, snow, wind, sun radiation and earthquakes. With its perfect resistance against to corrosion, protects your technological investments against environmental effects. Overall between the inner and outer skin there is 8mm thickness isolation material.

Isolation of Security Cabinet

Double skin structure with insulation is an effective solution to minimize environmental and territorial effects. The filtered panels allows ambient cold&fresh air to get in to the cabinet and reduces the internal heat naturally. Circulation fans are used to discharge the hot air from inside and by reducing heat it protects your active components

Cabinet Structure

Cabinets are designed as double skin structure, Material is DX51D+ZN275 gr/m2 zinc plated. According to EN 61587-1 / 6.4 IEC 60529 IP66 Protection class maintained based on Solid body entries and Water ingress. Fan and Filter combinations attached provides IP54 protection class. Fully EPDM gasketed front door is available. WK2 Antivandal lock with handle - 3 point locking helps maintaining the IP66 protection class. Mono-block welded structure, RAL 7035 light grey polyester outdoor painting finish protects the cabinet from corrosion. Un-flammable and fire retardant painting is applied.

Double Wall Structure

Double Wall and isolation infilled panels protects the equipments inside cabinet from external effects, mechanical impacts, vandalism, harsh environmental conditions. Pole type; outer skin is 1.5mm, inner skin 1.0mm, floor type; outer skin 3.0mm, inner skin 2.0mm DX51D+ZN275 zinc plated steel material structure with nano technology , high corrosion resistance polyester outdoor electrostatic painting applied. DX51D+ZN275 zinc plated steel material with painting. Between outer and inner skins there is 8mm isolation material.

Corner and Top Cover Structure

90 degree corner structured. Top cover is Crossfall Canopy.





Easy Pole Assembly

Special designed pole assembly brackets allows the cabinet to be hanged over the pole, after internal assembly is finished. Clamp Type Pole Fixing Kit is standard

Easy Floor Assembly

For the floor type model H100mm plinth is in standard product configuration. There is louver at back side of plinth for fresh air.

Filter and Fan System

2 way fan cycle is available. There are 2 units of 2 way fans with thermostat which are working independently on the upper and bottom sections of cabinet. The bottom 2 way fan unit takes the fresh air from the filter protected ventilation clean air inlet and discharge from the left side of the cabinet. The upper 2 way fan unit takes the fresh air from the filter protected ventilation clean air inlet and discharge from the top slots of canopy. Access to fans at bottom is possible by opening the front door, access to fans at top is possible by opening hinged top cover.



Camera Assembly

Hence there are 2 different fan systems on the cabinet, cameras should be installed to the pole but not on the enclosure. Assembly points and camera qty can be specified according to project applications.

DIN Rails

DIN rails in 50 cm length offered as an accessory to place industrial devices and electrical equipments.

19" Mounting Profile

There is mounting profile 19" 6U usable size 1,5mm thickness 1 set :2 pcs. Installed to upper section. All 19" sized accessories can be used inside cabinet. For suitable 19" accessories, you can check main catalogue.

Fixed Shelf

In this dual-volume product model, the partition separator is fixed as it has shelf feature and blocks the air passage from compartment to compartment. This compartment shelf is positioned between the lower and upper compartment. 60*300mm 2pcs brushed cable access are available between sections.



Lighting

By the automatic LED lighting unit that illuminates when door is opened and allows visibility to inside of cabinets during nights or dark environment conditions. Site operations can run continuously. It can be supplied as an accessory

Painting

Outdoor style polyester paint applied to resist environmental corrosive effects . It also resists to sun radiation. Standard applied color is RAL7035 Light Grey.



Top Cover Canopy Structure

Stopper mechanism is hidden inside top cover. This feature keeps the top cover open while installation or maintenance is in process on the field.

Front door and Lock System

In shipping configuration, Hidden hinge closing over flange double-skinned front door with the Antivandal WK2 standard 3 Points locking system handle and gasket, the front door provides maximum safety and sealing when the door is closed. It has a sealing gasket structure. Thanks to the excellent sealing Polyurethane based long life sealing system, provides excellent IP protection even cold/hot weather condition.



Door Switch

To receive a warning when the front door of cabinet opened or to enable or disable other systems, doors switches can be integrated. 1 or 2 switch integrations can be provided as an accessory.

Cable Management Rings

By using the self-threaded special screw system cable management rings - as an accessory - can be placed anywhere in the interior surface of the cabinet in desired quantities to set up cable Management infrastructure.

Door Switch

To receive a warning when the front door of cabinet opened or to enable or disable other systems , doors switches can be integrated. 1 or 2 switch integrations can be provided as an accessory

Cable Entry

There are 3 types of cable entry. Socket type, 90 degree protected pipe type and 45 degree protected pipe type . All 3 types have feature that can be used for the same product. 2pcs 90 degree protected pipe type cable entry are used in standard configuration. In case of need for different type cable entry, please choose cable entry model that you need from accessory chart. For Floor Type Model, PG gland cable entry available at bottom and back side of enclosure. 2xPG21, 1xPG29 and 2 Pcs 28mm sized PVC cover available. 70x140mm 2 pcs plastic cover plated cable entry is also available between sections.

Inner Doors

Inner door has a contribution to EN 60529 IP66 protection class structure. Every section is designed with lockable inner door structure. It is a support to outer door against dust and water.





POPLE TYPE
EXPLODED
VIEW

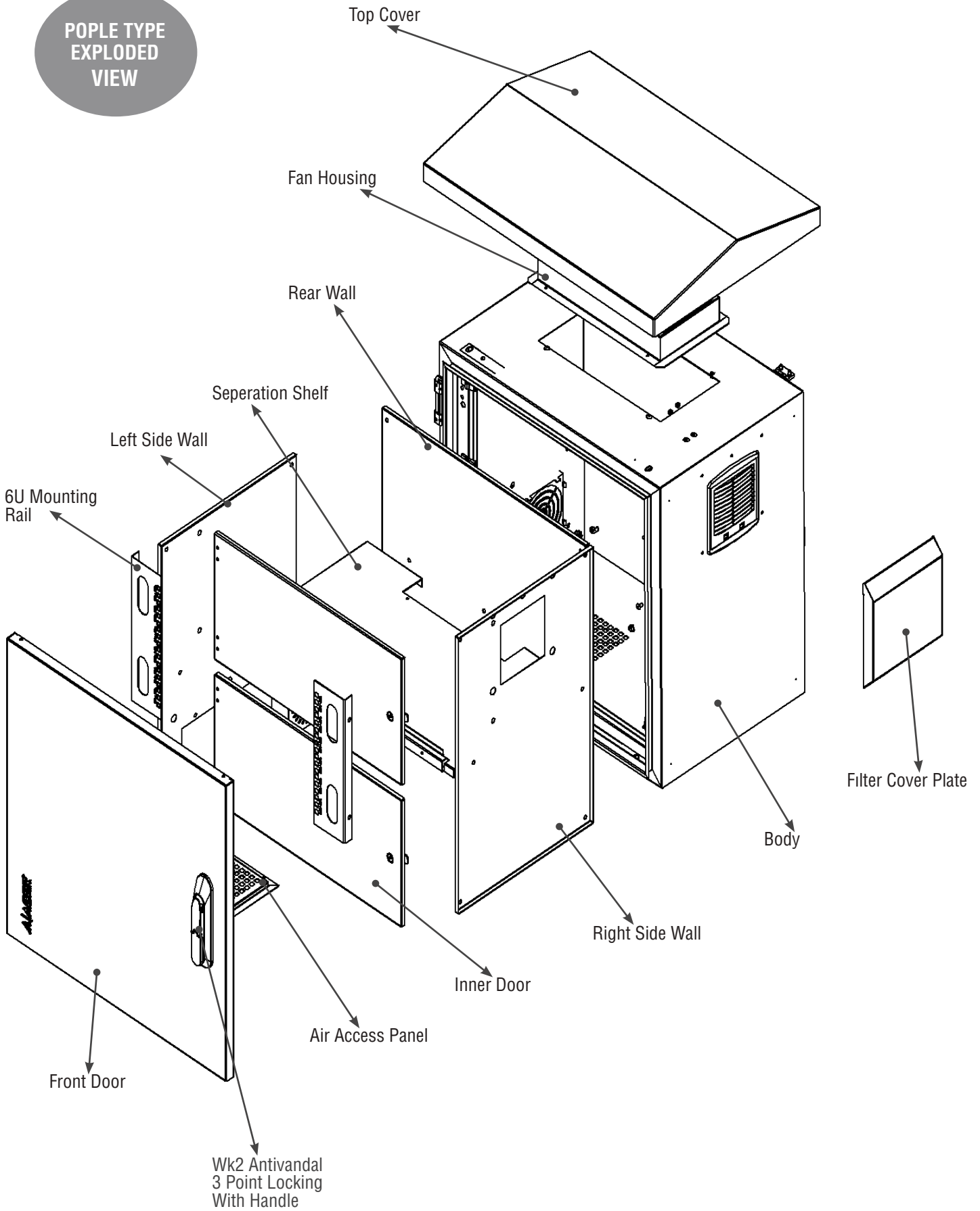

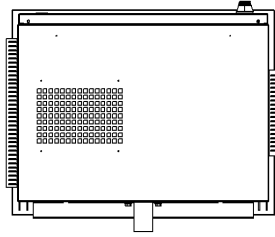

Bottom View

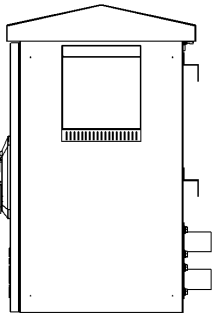

Side View

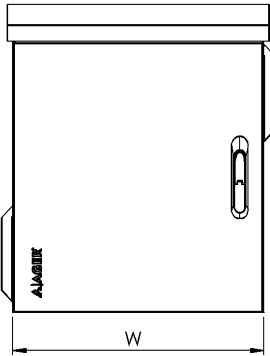

Front View

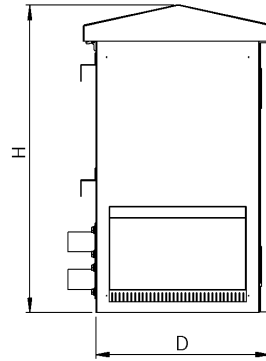

Side View

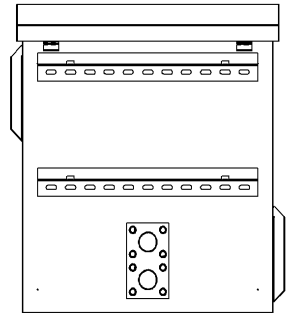

Rear View

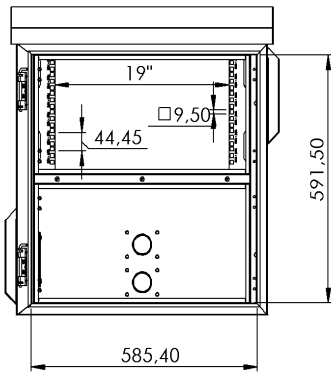

Front View Without Door

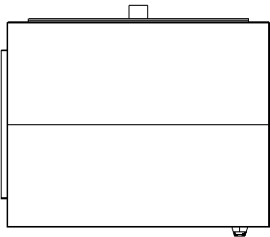

Top View

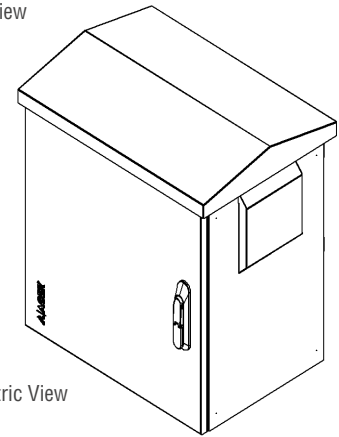

Isometric View

IP66 Field Enclosure Security Cabinet Pole Type

| Product Code | Product Description | Height Size in (U) | Width (W) (mm) | Depth (D) (mm) | Height (H) (mm) | Weight (Net) (kg) | Weight (Gross) (kg) |
|--------------------------|--|--------------------|----------------|----------------|-----------------|-------------------|---------------------|
| AG-OS12U6540B2-D-A151-M1 | IP66 W650mm*D400mm*H735mm Field Enclosure RAL 7035 (Pole Type -Outer Wall 1.5mm, Inner Wall 1.0mm) | - | 650 | 400 | 760 | 46 | 48 |
| AG-OS12U6545B2-D-A151-M1 | IP66 W650mm*D450mm*H735mm Field Enclosure RAL 7035 (Pole Type -Outer Wall 1.5mm, Inner Wall 1.0mm) | - | 650 | 450 | 760 | 53 | 55 |
| AG-OS12U6560B2-D-A151-M1 | IP66 W650mm*D600mm*H735mm Field Enclosure RAL 7035 (Pole Type -Outer Wall 1.5mm, Inner Wall 1.0mm) | - | 650 | 600 | 760 | 68 | 70 |



FLOOR TYPE
EXPLODED
VIEW

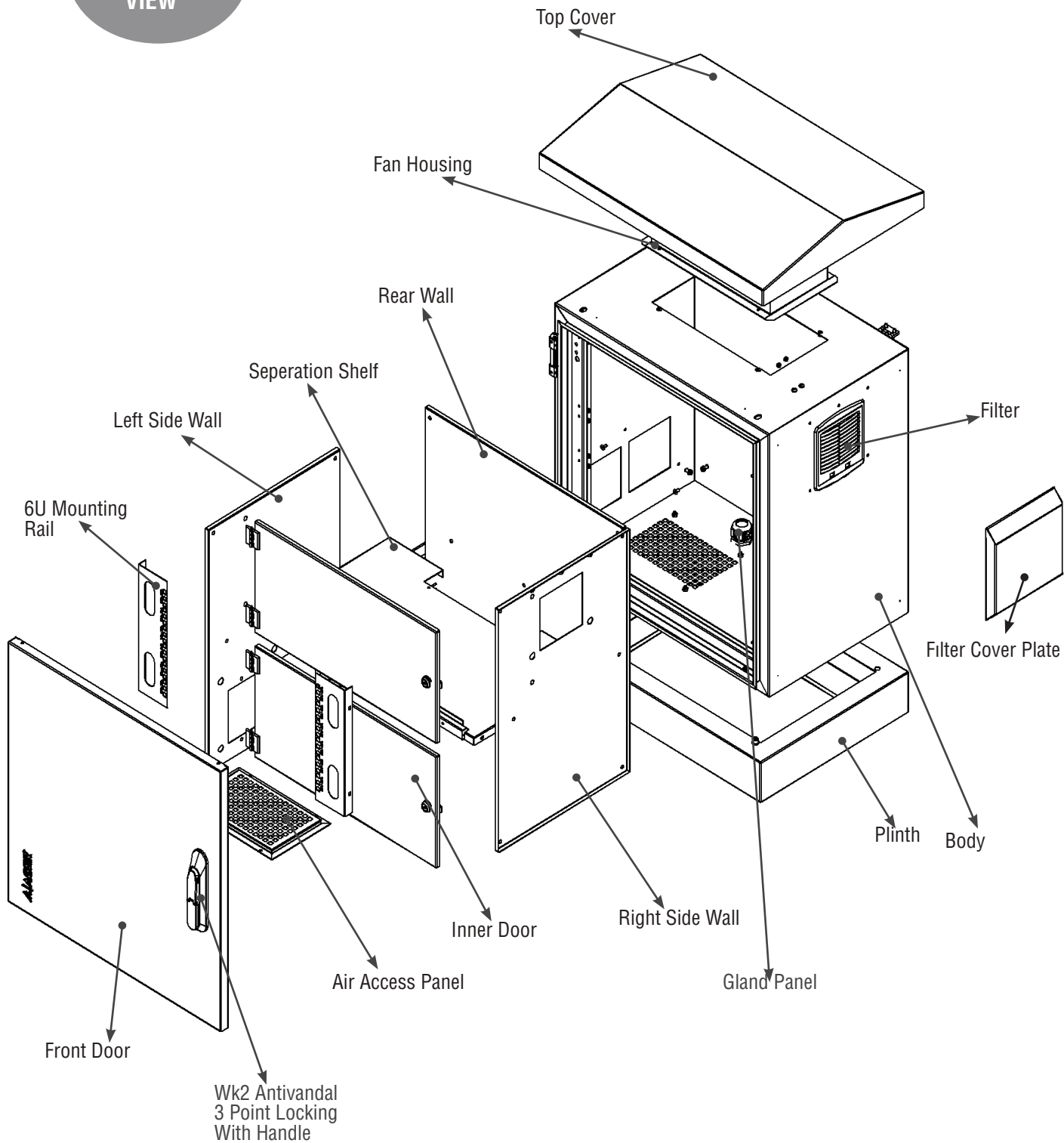

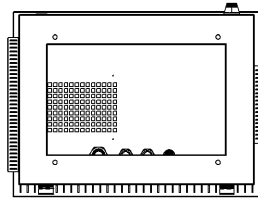

Bottom View

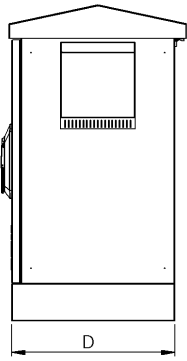

Side View

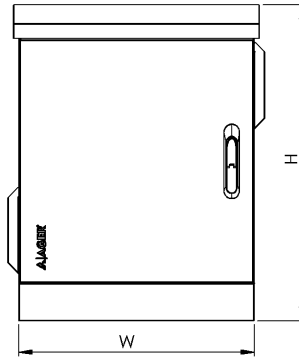

Front View

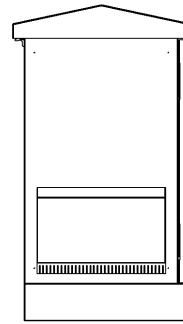

Side View

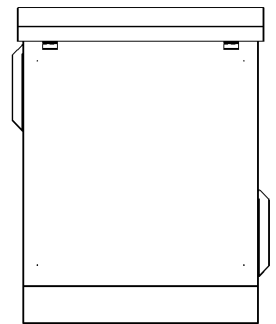

Rear View

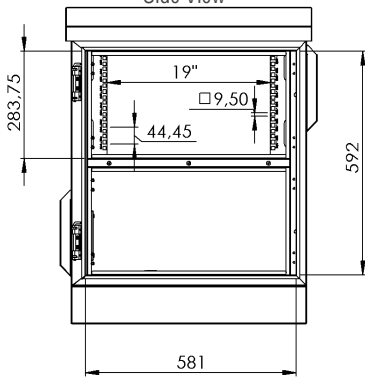

Front View Without Door

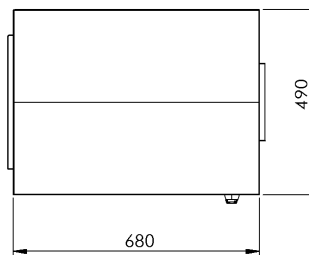

Top View

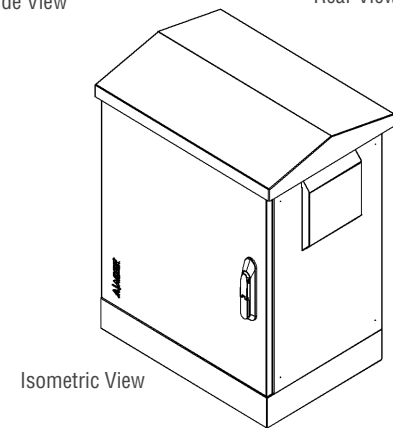

Isometric View

IP66 Field Enclosure Security Cabinet Floor Type







| Product Code | Product Description | Height Size in (U) | Width(w) (mm) | Depth (D) (mm) | Height (H) (mm) | Weight (Net) (kg) | Weight (Gross) (kg) |
|--------------------------|---|--------------------|---------------|----------------|-----------------|-------------------|---------------------|
| AG-OS12U6540B2-Y-A320-M1 | IP66 W650mm*D400mm*H735mm Field Enclosure RAL 7035 (Floor Type -Outer Wall 3mm, Inner Wall 2mm) | - | 650 | 400 | 860 | 46 | 48 |
| AG-OS12U6545B2-Y-A320-M1 | IP66 W650mm*D450mm*H735mm Field Enclosure RAL 7035 (Floor Type -Outer Wall 3mm, Inner Wall 2mm) | - | 650 | 450 | 860 | 53 | 55 |
| AG-OS12U6560B2-Y-A320-M1 | IP66 W650mm*D600mm*H735mm Field Enclosure RAL 7035 (Floor Type -Outer Wall 3mm, Inner Wall 2mm) | - | 650 | 600 | 860 | 68 | 70 |

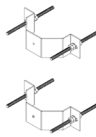
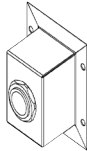
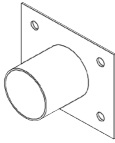

Accessory Selection

| Product Code | Product Description | Product Appearance |
|---------------------|--|--------------------|
| AA-30W | 50/60 Hz , 220V, 35mm DIN Rail Type Heater, 30W Heating Capacity, Aluminum Heater Body, Winter Thermostat Entegrated, PowerCable, 1,5-2,5mm ² Connection Terminal Entry 85° C Body Heat, H75mm | |
| AA-50W | 50/60 Hz , 220V, 35mm DIN Rail Type Heater, 50W Heating Capacity, Aluminum Heater Body, Winter Thermostat Entegrated, PowerCable, 1,5-2,5mm ² Connection Terminal Entry 85° C Body Heat, H85mm | |
| AA-75W | 50/60 Hz , 220V, 35mm DIN Rail Type Heater, 75W Heating Capacity, Aluminum Heater Body, Winter Thermostat Entegrated, PowerCable, 1,5-2,5mm ² Connection Terminal Entry 125° C Body Heat, H105mm | |
| AA-100W | 50/60 Hz , 220V, 35mm DIN Rail Type Heater, 100W Heating Capacity, Aluminum Heater Body, Winter Thermostat Entegrated, PowerCable, 1,5-2,5mm ² Connection Terminal Entry 125° C Body Heat, H120mm | |
| AA-150W | 50/60 Hz , 220V, 35mm DIN Rail Type Heater, 150W Heating Capacity, Aluminum Heater Body, Winter Thermostat Entegrated, PowerCable, 1,5-2,5mm ² Connection Terminal Entry 125° C Body Heat, H190mm | |
| AA-HGT | Ager Mechanic Analog Higrostat- 4% RH (± 3% tolerance) %40-90 Rh, 2,5mm ² clemence terminal, 35mm DIN rail Type | |
| AA-HGT-THM | Ager Mechanic Analog Higrostat 4% RH (± 3% tolerance) %40-90 Rh + Thermostat 0-60°C, 2,5mm ² clemence terminal, 35mm DIN Rail Type | |
| AA-PRZ-ONF-XU6P-PLS | 6 way ON/OFF Switched Plastic Pdu With 2 Meter Cable, Schuko Type DIN49441 Plug, 220-250VAC | |
| AA-PRZ-SGT-1U6P-SC | 6xDIN49440 Socket Schuko Power Stripe, 19" 1U, aluminium housing, 1x16A cct breaker, 4000 Watt, 250V AC, 3x1.5mm ² , 2,5m cable, DIN 49441 plug, CE approval | |
| AA-KDG-KKM-4430-LG | Cable Rings 44x30mm (1 set : 5 pcs) | |
| AA-DGR-AYD-1U0T-XX | Lighting Module with Sensor, Automatically Led Lighting On while Magneted Doors Are Open. | |
| AA-RAF-RMR-1U20-LG | 1U D=200mm 19" Rack Mount Shelf, 2 point fixing, for all cabinets at 19" provision, Load Capacity 30 kg | |

Accessory Selection

| Product Code | Product Description | Product Appearance |
|--------------------|--|---|
| AA-OU-PL-KIT-B2-HD | Heavy Duty Type Pole Assembly Kit |  |
| AA-OU-PL-KIT-GL-EC | Clamp Type Pole Assembly Kit |  |
| AA-KGM-SKT-01 | Socket Type Protection Cable Entry Unit |  |
| AA-KGM-BRT-01 | 90° Protection Pole Type Cable Entry Unit |  |
| AA-KGM-BRT-02 | 45° Protection Pole Type Cable Entry Unit |  |
| AA-KLT-3P-WK2 | 3 point locking WK2- against vandalism |  |
| AA-KLT-3P-ZMC | 3 point locking with handle- Zamac |  |
| AA-SWT-1L | Door Stopper, Metal Mounting Bracket And Screw Set Included - 1 pcs Switch Included. |  |
| AA-WOT-DIN | W automat DIN RAIL with 50cm height Galvanised, including screw set |  |

**Ager Compact Security Cabinet-Field Enclosure Air Conditioner**

| Product Code | Product Description | Width (w) (mm) | Depth (d) (mm) | Height (h) (mm) |
|--------------|---|----------------|----------------|-----------------|
| AA-500 | Ager Mini Type Compact Security Cabinet-Field Enclosure Air Conditioner AA-500 L35L35 450W, L35L50 380W, 50/60Hz, 198-252V, Ip65 System Ral 7035 | 335 | 265 | 400 |

| Technical Information | AA-500 |
|-----------------------------|---------------------------------|
| Cooling Capacity L35 L35 | 450W |
| Cooling Capacity L35 L50 | 380W |
| Type of Refrigerator | R 134a |
| Amount of Refrigerator | 290 gr |
| Thermostat Factory Settings | 34°C |
| Hysteresis | 4 K |
| External Fan Blow | 540 m³/h |
| Internal Fan Blow | 290 m³/h |
| Rated Frequency | 50/60 Hz |
| Standard Power Supply | 198 V..252 V |
| Power absorbed | 312 W |
| Running Current | 1.6 A |
| Starting Current | 5.2 A |
| Weight (kg) | 19 kg |
| Width x Depth x Height | 400*335*265 (mm) |
| Housing Material | Stainless Steel |
| Paint | RAL 7035 Polyester Outdoor Type |
| Mounting Type | Panel Type Assembly |
| Protection Class | IP 65 |
| Nominal Working Temperature | (+)15°C / (+)55°C |
| Compressor | Danfoss |
| Fans | Ebm Papst |
| Control / Monitoring | Digital Control Screen |