

# WALL MOUNTED **AGENA BASE** SERIES



**AGER** Agena Base series wall mounted cabinets; serve the purpose of small or medium-sized network installation. Maximizing the load capacity and strength of the cabinet, the main carcass profiles riveted to the upper and lower frames of the cabinet's steel structure. Mounting rails can be adjusted along the depth of the cabinet as per your needs. The wall-mountable structure increases functionality and provides multiple solutions in small areas. In addition to heavy-duty structure, metal frame and glass front door completes elegant and aesthetic visuality.



## Colour Options

RAL7035 Light Gray

RAL9005 Black



### **Front Door**

Front door model is full-length glass door with metal frame; 4mm smoked, tempered and high fracture resistance with cam lock. Front glass door with spring-loaded hinge system allows changing opening direction when required without any use of tools.

### **Structure**

Maximizing the load capacity and strength of the cabinet, the main carcass profiles riveted to the upper and lower frames of the cabinet's steel structure.

### **Size Options**

With two different depth dimensions (450mm - 600mm) and 5 different U height options (7U - 9U - 12U - 16U - 20U), with 10 different size options, Agena Base series provides solutions for all kinds of needs about optimum volume and cost.

### **Ventilation**

---

Two ventilation holes on the top cover allow to passive ventilation by convection when the fan module is not assembled and active ventilation when the fan module is assembled.

### **Cable Entry**

---

3 way cable access provided by the cable entry holes on the rear panel, top and bottom sheet.

### **Side Panels**

---

Easily removable side panels provide quick access to inside enclosure. Cam lock mechanism is optional.

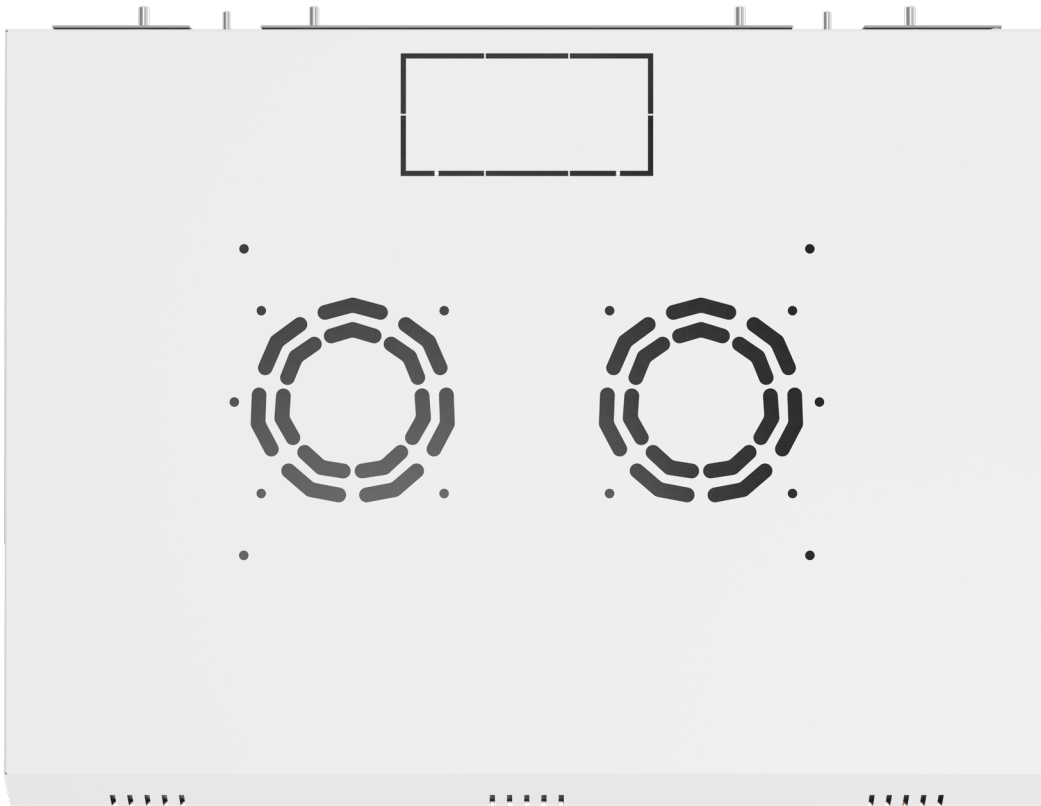



**AGER**

WALL MOUNTED **AGENA BASE** SERIES

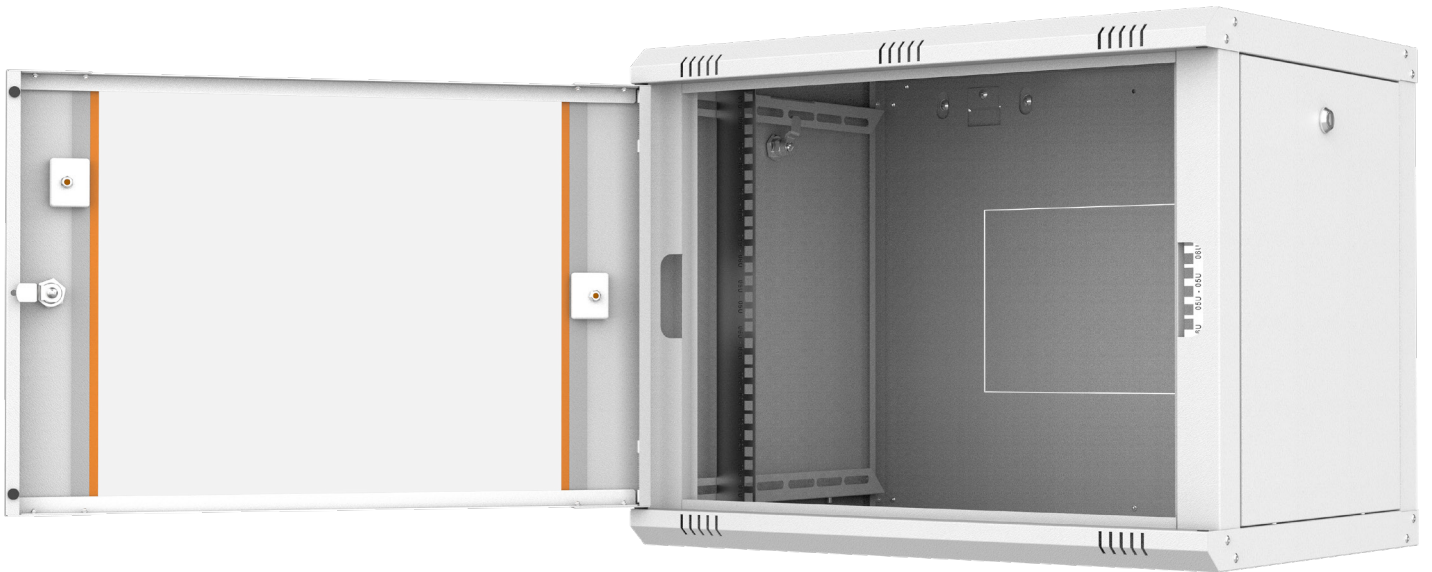

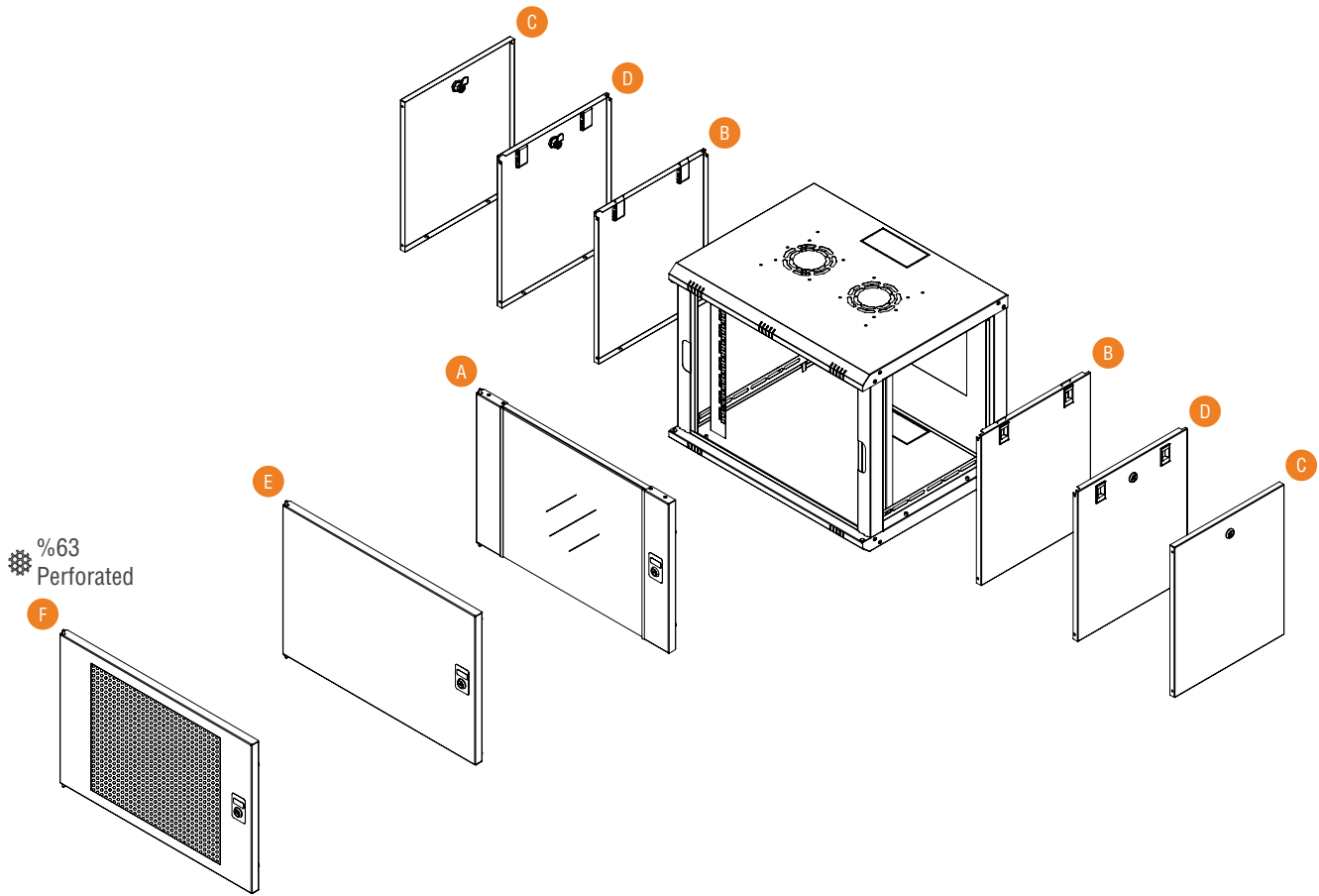

AG	AB	07U	60	45	B1	A	0	B	B	A	M1
1	2	3	4	5	6	7	8	9	10	11	12

1. Company product coding system's initial character is AG that stands for AGER.
2. Product Series Code. AB stands for Agena Base Wall Mounted.
3. Numeric Character defining the height of the cabinet. Depending on model differences, between 07 to 20 height variety available. U Height Alfanumeric Notation is fixed, not editable. 1U is 44.45mm.
4. The First two Digits of the width information. 60 for W:600mm cabinets.
5. The First two Digits of the depth information, 45 for D:450mm cabinets, 60 for D:600mm cabinets.
6. Colour Codes. B1 for Light Gray RAL 7035. S1 for Black RAL 9005.
7. Front door variation number.\*
8. Rear door variation number\*
9. Right Side Panel variation number.\*
10. Left Side Panel variation number..
11. Version information. A- Standart version. The version is changed alphabetically when any alteration made to the cabinet
12. Indicate how the cabinets' shipped. M1 for assembled, D1 for flat pack.

Wall Type **Agena Base Series** DOOR Options

- A Single Opening, Flat Shaped, Glass Front Door with Side Frame, Single Point Locking with Cam Lock
- B Single Opening, Flat Shaped, Solid Metal, Snap Locking and Two Point Locking with sliding lock, Panel
- C Single Opening, Flat Shaped, Solid Metal, Single Point Locking with Cam Lock, Panel
- D Single Opening, Flat Shaped, Solid Metal, Snap Locking and Single Point Locking with Cam Lock, Panel
- E Single Opening, Flat Shaped, Solid Metal Front Door, Single Point Locking with Cam Lock
- F Single Opening, Flat Shaped, Complete Framed %63 Perforated, Metal Front Door, Single Point Locking with Cam Lock

\* YOU CAN CHECK THE DOOR OPTIONS FOR DOOR AND PANEL VARITIONS...

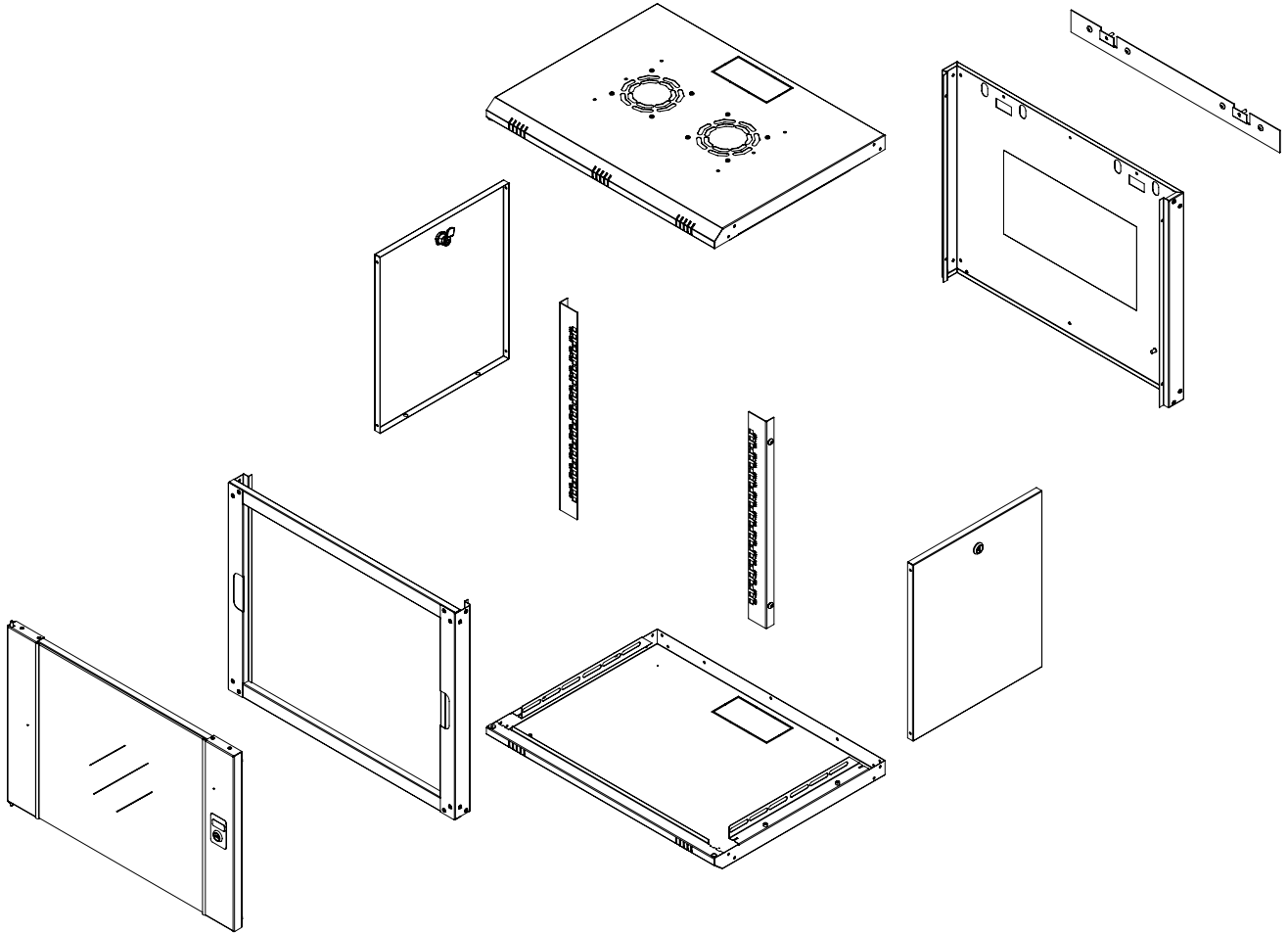

### Material

- 0.8 mm DKP
- IP Classification**
- As a standard IP20
- IP40 when solid metal panel applied for all access

### Color Options

- RAL9005 Black
- RAL7035 White

### Doors

- Door options are available.
- Single point locking system
- Doors can be opened to 236 degree.
- Doors can be opened to left or right direction

### Mounting Rails

- 19" Mounting rails; adjustable in depth of the cabinet
- 1.5mm DX51D galvanic

### Side Panels

- Locking system is available, Side panels are removable.

### Loading Capacity

- Recommended up to 80 kg Loading capacity



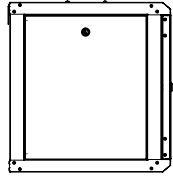

SIDE VIEW

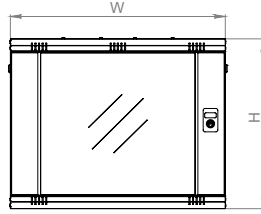

FRONT VIEW

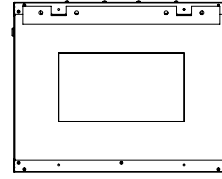

REAR VIEW

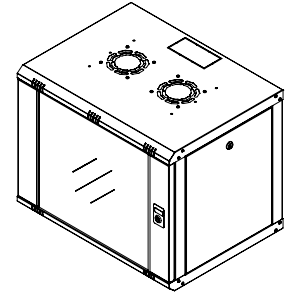

ISOMETRIC VIEW

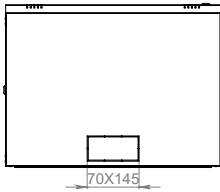

BOTTOM VIEW

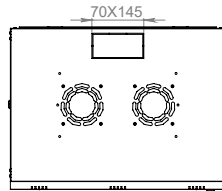

TOP VIEW

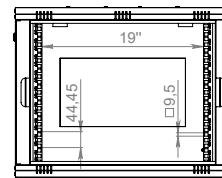

FRONT VIEW WITHOUT DOOR

19" Ager Wall Mounted Agera Base Series

Product Code	Product Description	Height Size in (U)	Genişlik (Mounting Railer Arası)	Width (w) (mm)	Depth (D) (mm)	Height (H) (mm)	Weight (Net) (kg)	Weight (Gross) (kg)
AG-AB07U6045XX-0000-A-YY	07U 19" Ager Agera Base Wall Mounted Cabinet W=600mm D=450mm	7U	19"	600	450	385	18	19
AG-AB09U6045XX-0000-A-YY	09U 19" Ager Agera Base Wall Mounted Cabinet W=600mm D=450mm	9U	19"	600	450	474	21	22
AG-AB12U6045XX-0000-A-YY	12U 19" Ager Agera Base Wall Mounted Cabinet W=600mm D=450mm	12U	19"	600	450	607	26	27
AG-AB16U6045XX-0000-A-YY	16U 19" Ager Agera Base Wall Mounted Cabinet W=600mm D=450mm	16U	19"	600	450	785	32	34
AG-AB20U6045XX-0000-A-YY	20U 19" Ager Agera Base Wall Mounted Cabinet W=600mm D=450mm	20U	19"	600	450	963	38	40
AG-AB07U6060XX-0000-A-YY	7U 19" Ager Agera Base Wall Mounted Cabinet W=600mm D=600mm	7U	19"	600	600	385	21	22
AG-AB09U6060XX-0000-A-YY	9U 19" Ager Agera Base Wall Mounted Cabinet W=600mm D=600mm	9U	19"	600	600	474	24	25
AG-AB12U6060XX-0000-A-YY	12U 19" Ager Agera Base Wall Mounted Cabinet W=600mm D=600mm	12U	19"	600	600	607	29	30,5
AG-AB16U6060XX-0000-A-YY	16U 19" Ager Agera Base Wall Mounted Cabinet W=600mm D=600mm	16U	19"	600	600	785	35	36,5
AG-AB20U6060XX-0000-A-YY	20U 19" Ager Agera Base Wall Mounted Cabinet W=600mm D=600mm	20U	19"	600	600	963	42	43,5

XX = Colour Code, B1 White RAL 7035, S1 Black RAL 9005, during order please specify the colour choice  
 Please consider when used levelling feet 30mm add to Height, in castor add 80mm  
 0000 = Please check the Door Options page  
 YY = M1 for pre-assembled, D1 for flat pack