

OUTDOOR IP66 CABINETS



AGER IP 66 OUTDOOR Cabinets are suitable for IT and telecommunication solutions in outdoor conditions; protection against dust, accidental contact and water according to the EN60529 regulation. Manufactured from DX51D+ZN275 material. Provides IP66 protection class by polyurethane seal on door. Wing Knob lock is resistant against vandalism. RAL7035 light gray polyester electrostatic powder paint is applied on the monoblock structure to protect the cabinet from corrosion, heat, icing and environmental effect.





Filter System

Filters are located downside of the cabinets. Through the filter grids, cold, fresh air enters and fans discharge the heated air and humid. The cleanable and replaceable air filter is used in side filter grids. If requested fan unit can be mounted to the filter.

Locking Mechanism

7U & 9U have one point locking system and 12U & 16U have two-point locking systems, both of them with Zamac wing knob cam lock which gives full security.

Bottom Cable Entry

At the bottom cable entry can be customized for the outdoor cabinets. Standard cable entry is micro-jointed on the closing plate, sized are suitable for 1XPG29 and 3XPG21 gland.

Protection Paint

Polyester paint which is suitable for outdoor conditions applied. It protects against Environmental influence and weather conditions. Standard colour is RAL 7035 polyester outdoor paint. As an option, primer can be applied before painting for higher protection and longevity

Material

- 1.2 mm GLV - DX51D

IP Classification

- As a standart IP66

Color Options

- RAL7035

Doors

- Wing Knob Mechanism

Mounting Rails

- 19" Mounting Rails 1.5mm DX51D GLV

Loading Capacity

- 100 kg loading capacity

Bottom Panel

- A filter module with ventilation shutter.

Ventilation

- There is a fan module with thermostat that can be mounted on the top.



Ventilation System

As an option 2 fans with thermostat on the top sheet ensure air circulation, fans provide hot air outlet and side filters allows cool air inlet.



Ventilation System

As an option 2 fans with thermostat on the top sheet ensure air circulation, fans provide hot air outlet and side filters allows cool air inlet.

Water and Dust Proof

Polyurethane gasket is available on the front door and top cover.

Easy Mounting

Cabinet can be easily mounted to the wall due to 4 pcs mounting kit at the back of the cabinet

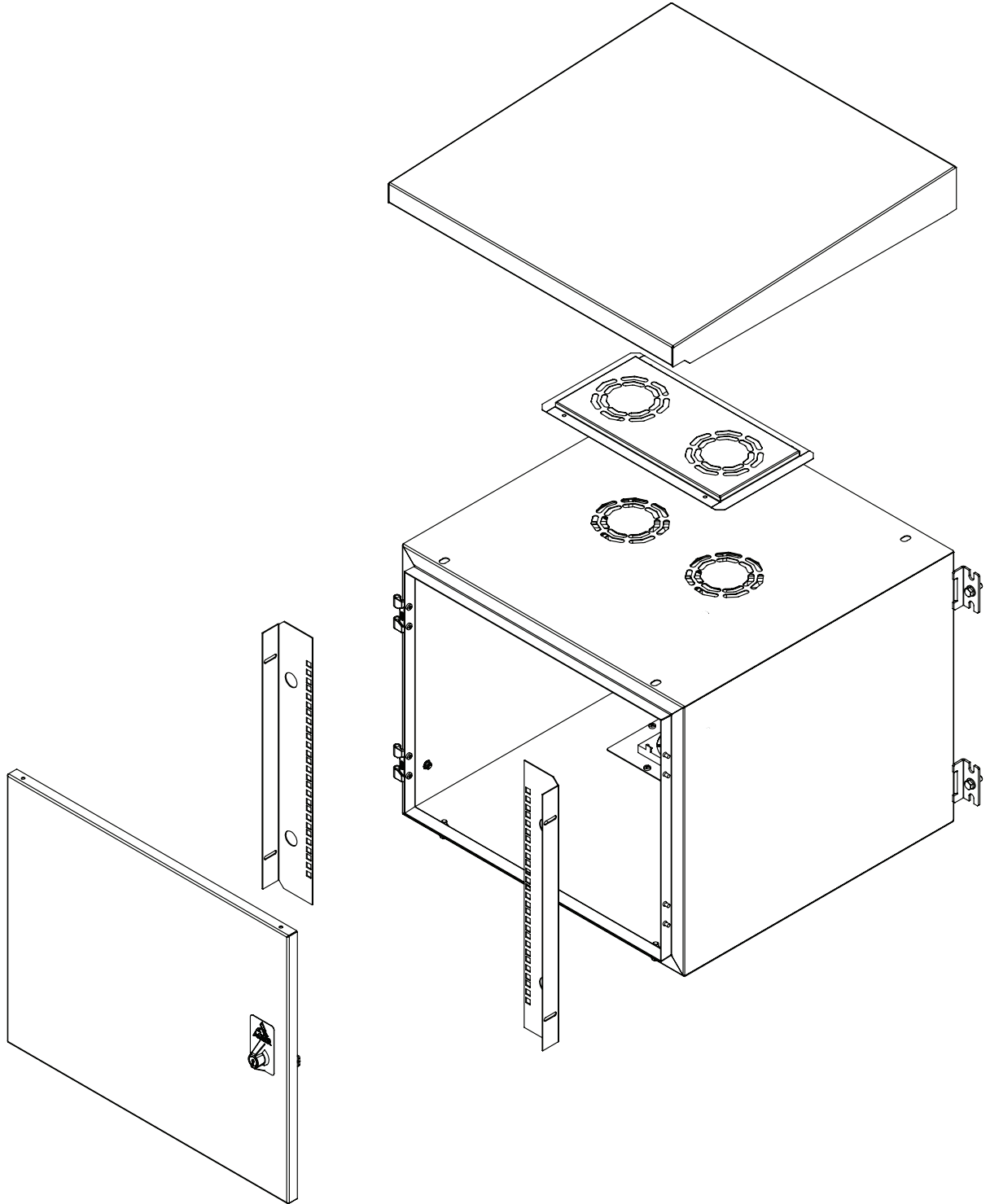

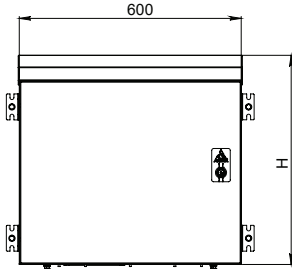

Front View

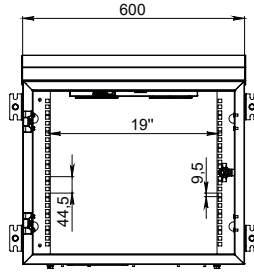

Front View Without Door

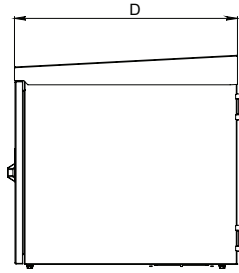

Side View

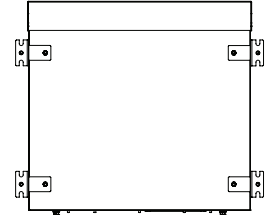

Rear View

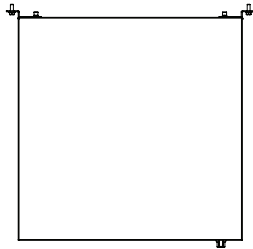

Top View

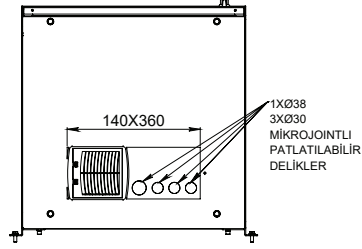

Bottom View

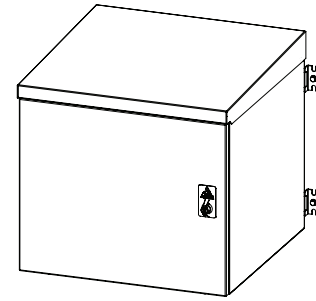

Isometric View

AGER OUTDOOR WALL MOUNTED CABINET

Product Code	Product Description	Height (U)	Width (W) (mm)	Depth (D) (mm)	Height (H) (mm)	Weight (Net) (kg)	Weight (Gross) (kg)
AG-OB07U6045B2-D-A-M1	07U 19" IP66 Outdoor Wall Mounted Cabinet W=600mm D=450mm	7U	600	450	470	31	32
AG-OB09U6045B2-D-A-M1	09U 19" IP66 OWall Mounted Cabinet W=600mm D=450mm	9U	600	450	559	33	34
AG-OB12U6045B2-D-A-M1	12U 19" IP66 Wall Mounted Cabinet W=600mm D=450mm	12U	600	450	692	37	38
AG-OB16U6045B2-D-A-M1	16U 19" IP66 OWall Mounted Cabinet W=600mm D=450mm	16U	600	450	870	41	43
AG-OB07U6060B2-D-A-M1	07U 19" IP66 Outdoor Wall Mounted Cabinet W=600mm D=600mm	7U	600	600	470	37	38
AG-OB09U6060B2-D-A-M1	09U 19" IP66 Outdoor Wall Mounted Cabinet W=600mm D=600mm	9U	600	600	559	40	41
AG-OB12U6060B2-D-A-M1	12U 19" IP66 Outdoor Wall Mounted Cabinet W=600mm D=600mm	12U	600	600	692	43	45
AG-OB16U6060B2-D-A-M1	16U 19" IP66 Outdoor Wall Mounted Cabinet W=600mm D=600mm	16U	600	600	870	49	51

XX = Color Code, B1 White refers to RAL 7035, S1 Black refers to RAL 9005, this information should be conveyed to the representative at the order stage.
 Please add 30mm to the H value when using Pinion Feet and 80mm for Wheel Assembly.
 0000 = See cover options page.
 YY = M1 is used for assembled shipment and D1 is used for disassembled shipment