

WALL MOUNTED **SLIMLINE** SERIES

500mm **SLIMLINE** Series Wall Mounted Cabinets

The Product Line is designed for small network infrastructure needs such as small offices and home offices. Thanks to its decorative design, it is suitable for applications that take up little space on the wall in all infrastructures such as hotels, hospitals, and laboratories.

Mostly customers complain about the space occupied by Wall-mounted deep wall-mounted cabinets in network applications. Generally, such complained locations are hotel lobbies, small office infrastructures, hospitals or elite offices. Eliminating this problem, **SLIMLINE** cabinets offer comfort to users with their 165mm depth on the wall.

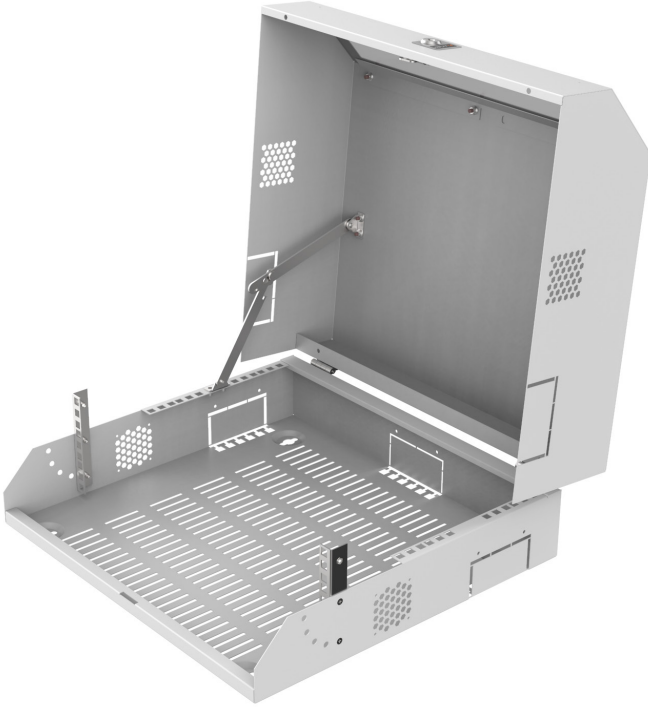

Product Dimensions are W:500mm D:475mm H:165mm

SLIMLINE offers the possibility of use in a lowered ceiling, in a 600x600mm raised floor, or on or under a tabletop.

Please contact the authorized person for your requests in different sizes.

The front cover is hinged type and can be opened to the right, left, up or down, depending on the way the product is mounted on the wall or in the relevant location.

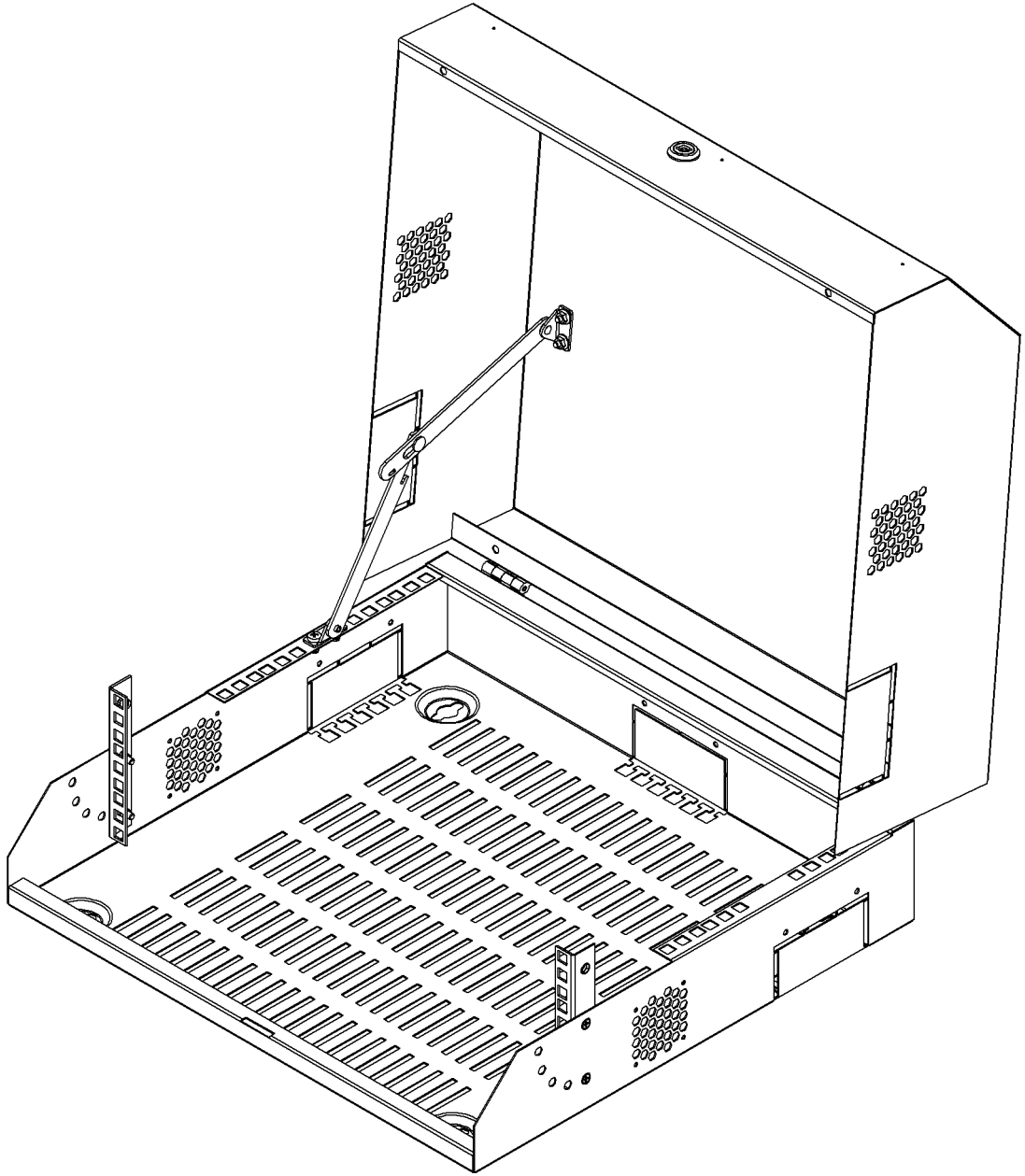
**Material**

- 1 mm DKP

IP Classification

- As a standard IP20

Color Options

- RAL9005 Black
- RAL7035 White

Doors

- Single point locking system
- Doors can be opened to 110 degree.

Mounting Rails

- 1.2mm DX51D galvanic
- 19" Mounting rails; adjustable in depth of the cabinet

Monobloc Structure

- There are wall mounting holes on the back.
- There are detachable cable passage holes with micro joints on the back and side.

Loading Capacity

- Recommended up to 50 kg loading capacity

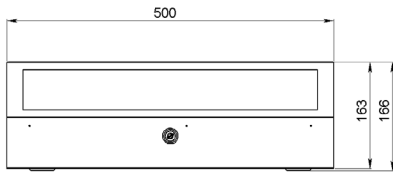

Front View

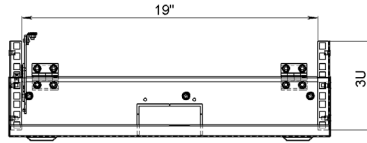

Front View Without Door

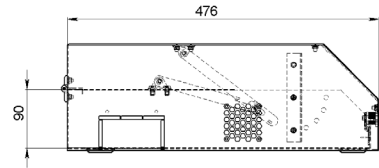

Side View

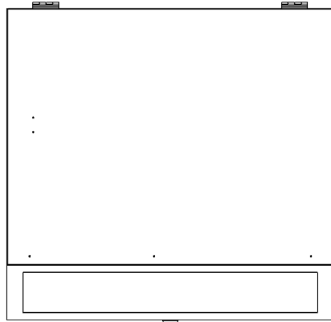

Top View

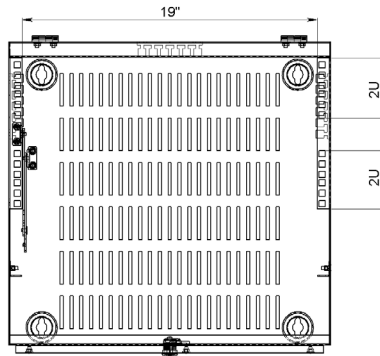

Top View Without Panel

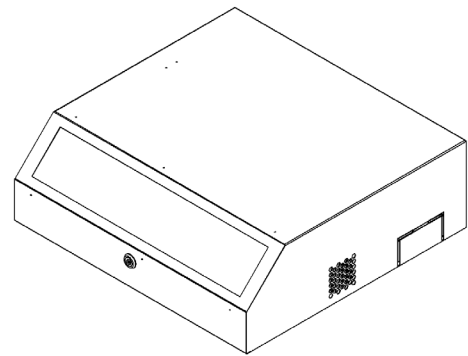

Isometric View

19" Wall Mounted SLIMLINE Series Cabinet

Product Code	Product Description	Height Size in U (U)	Width (W) (mm)	Depth (D) (mm)	Height (H) (mm)	Weight (Net) (kg)	Weight (Gross) (kg)
AG-SL07U5048XX-C-A-M1	7U 19" (3U+4U) Wall Mounted SLIMLINE Cabinet W=500mm D=480mm	7	500	480	165	7	8,5

XX = Colour Code, B1 White RAL 7035, S1 Black RAL 9005, during order please specify the colour choice.
 YY =M1 for pre-assembled, D1 for flat pack.